



NAVIENT

Condensing Combi-Boilers

LP Gas & High Altitude Conversion Guide

Model

NCB-190/060H NCB-190/080H
 NCB-240/110H NCB-240/130H
 NCB-250/150H

WARNING

- Be careful not to confuse the LP CONVERSION KIT and HIGH ALTITUDE CONVERSION KIT. Do NOT use the HIGH ALTITUDE CONVERSION KIT for NG when converting to LP gas.
- Make sure that the conversion is completed with the proper orifice. If the installed orifice does not conform to the specifications in Table 1, incomplete combustion may occur, resulting in personal injury or property damage.

This boiler is configured for Natural Gas at the factory.

- If conversion to Propane Gas is required by the boiler, use the LP CONVERSION KIT supplied with the boiler.

- Note**
- For NG high altitude conversion, use the HIGH ALTITUDE CONVERSION KIT.
 - For LP high altitude conversion, use the LP CONVERSION KIT. Note that the Gas Orifice from the LP CONVERSION KIT covers the boiler's installation at an altitude of 0 to 10,100 ft.

WARNING

This conversion kit must be installed by a qualified service agency* in accordance with Navien's instructions and all applicable codes and requirements of the authority having jurisdiction. The information in these instructions must be followed to minimize the risk of fire or explosion or to prevent property damage, personal injury or death. The qualified service agency is responsible for the proper installation of this kit. The installation is not proper and complete until the operation of the converted appliance is checked as specified in the manufacturer's instructions supplied with the kit.

* A qualified service agency is any individual, firm, corporation or company which either in person or through a representative is engaged in and is responsible for the connection, utilization, repair or servicing of gas utilization equipment or accessories; who is experienced in such work, familiar with all precautions required, and has complied with all of the requirements of the authority having jurisdiction.

In Canada: The conversion shall be carried out in accordance with the requirements of the provincial authorities having jurisdiction and in accordance with the requirements of the CAN-B149.1 and CAN1-B149.2 Installation Code.

Tools Required:

- Phillips Screwdriver
- Flathead Screwdriver
- ⁵/₃₂ in or 4 mm Allen Wrench
- Combustion Analyzer or Dual Port Manometer
- Gas Leak Detector

Procedure:

1. Turn off both gas and water supply to the boiler.
2. Unfasten the 4 latches (2 at the top and 2 at the bottom) to remove the front cover and gain access to the internal components.

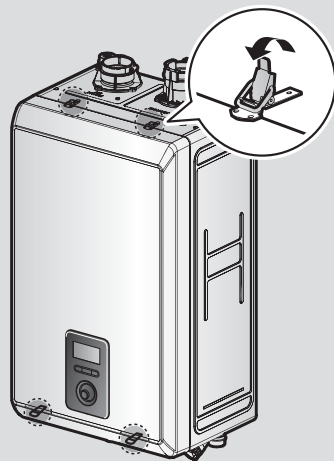

Figure 1. NCB-H Series Front Cover

3. Remove the front cover and place it in a safe location to prevent accidental damage.

4. With the internal components exposed, locate the gas inlet pipe and the gas valve, as shown in Figure 2.

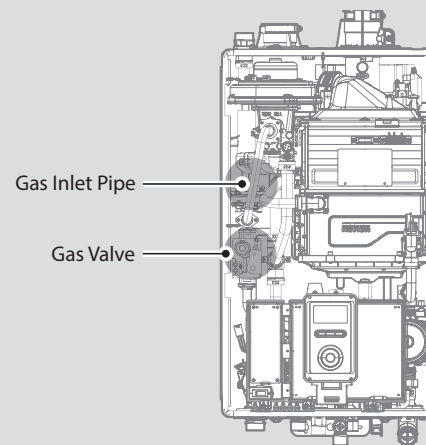

Figure 2. NCB-H Series Internal Components

5. Use a Phillips screwdriver to remove the two screws at location A - the connection below the gas valve where it connects to the pipe. See Figure 3 for reference. Once the screws are removed, carefully separate the pipe from the gas valve.
6. Once the gas inlet pipe is detached from the gas valve, find location B - the connection above the gas valve where it is attached to the fan motor assembly. Carefully remove the four screws by hand using a Phillips screwdriver and pull the gas valve away from the fan assembly to access the gas orifice.

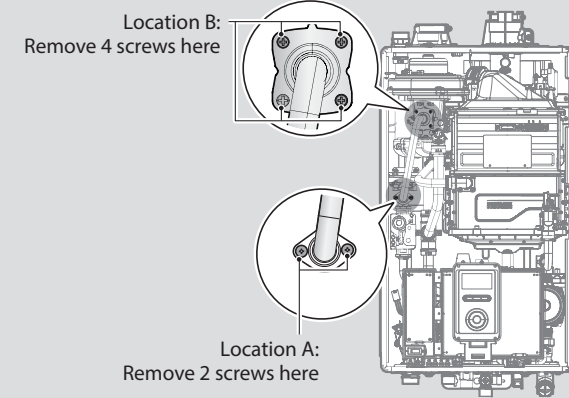

Figure 3. Detaching Gas Valve from Gas Inlet Pipe and Fan Motor Assembly

7. Once the Gas Orifice is exposed, remove the two screws that hold the part in place. Remove the Gas Orifice from its housing and prepare the new Gas Orifice for the LP conversion for installation.

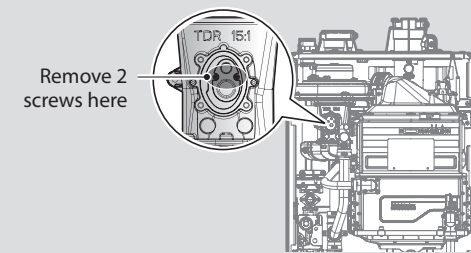

Figure 4. Access to Gas Orifice in Fan Assembly

1 3
2 4

Included Items:

- Gas Orifice (refer to below table)

NCB-190/060H, 190/080H Orifice Identification

Gas Type	NG	LP
Altitude	0-5,399 ft	0-10,100 ft
Orifice	Factory Installed	For LP
Orifice Size	Ø4.50/Ø6.30	Ø3.65/Ø4.95

NCB-240/110H, 240/130H, 250/150H Orifice Identification

Gas Type	NG	LP
Altitude	0-5,399 ft	0-10,100 ft
Orifice	Factory Installed	For LP
Orifice Size	Ø4.80/Ø7.50	Ø3.90/Ø5.65

Table 1. Orifice Size

WARNING

- DO NOT adjust or attempt to measure gas valve outlet pressure. The gas valve is factory-set for the correct outlet pressure. This setting is suitable for natural gas and propane, requiring no field adjustment.
- Attempting to alter or measure the gas valve outlet pressure could result in damage to the valve, causing potential severe personal injury, death or substantial property damage. Navien NCB-H boilers are shipped ready to fire natural gas ONLY.

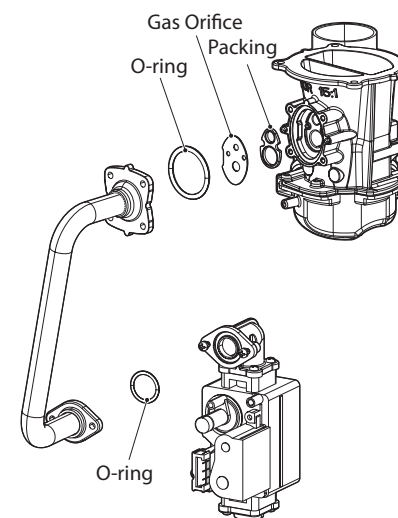

Figure 5. Exploded View of Gas Pipe Assembly

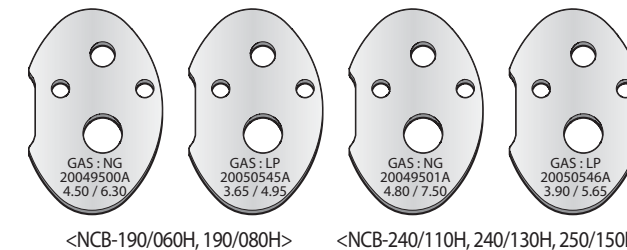
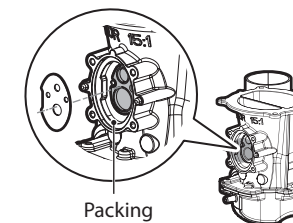

Figure 6. Orifice Identification

8. Remove the Gas Orifice, ensure that the packing is properly seated inside the port, and then install the new Gas Orifice for use with LP gas. Ensure that the Orifice is properly seated on the packing inside the port before proceeding to the next step.



9. Replace the gas valve outlet adapter to its original position and use all screws to secure all connections.

Note Do not overtighten as this may damage or crack the components.

! DANGER

Inspect the O-ring between the gas valve and gas valve inlet adapter whenever they are disassembled. The O-ring must be in good condition and must be installed. Failure to comply will cause a gas leak, resulting in severe personal injury or death.

10. Set the PCB Dip Switch to change the gas type. For LP, set Dip Switch 2 #1 to ON. For NG, set DIP SW2 #1 to OFF.

Note Set the PCB DIP Switches by altitude according to the table in the warning below.

! WARNING

Ensure that you have turned off the power to the boiler before accessing the DIP switches.

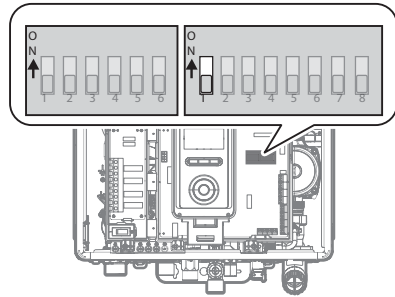

! WARNING

Switch	Function	Setting	Comment
1	Gas Type	Natural Gas	1-OFF
		Propane Gas	1-ON
2&3	High Altitude	0-1,999 ft (0-609m)	2-OFF, 3-OFF
		2,000-5,399 ft (610-1,645m)	2-ON, 3-OFF
		5,400-7,699 ft (1,646-2,346m)	2-OFF, 3-ON
		7,700-10,100 ft (2,347-3,078m)	2-ON, 3-ON

Refer to Table 1 on page 2.

Note

- This unit may be installed at elevations up to 10,100 ft (3,078 m) for use with natural gas and propane. To use the unit at a specific altitude, the DIP Switches should be set as described above.
- High Altitude: Above 2,000 ft (610 m), the unit will de-rate by 3% for each 1,000 ft (305 m) of altitude gain.

Note The set screw is located behind the screw-on cover. This must be removed first.

d. Activate multiple zones and set the boiler to operate at 2-stage D. MAX mode. Measure the CO₂ value at high fire. If the CO₂ values do not match Table 2 at high fire, do not adjust the gas valve. Check for the proper Gas Orifice.

! DANGER

Improper gas valve settings can cause severe personal injury, death or substantial property damage.

Option 2. Using Digital Manometer

a. Open the offset pressure port by loosening the screw two turns as shown in Figure 9.

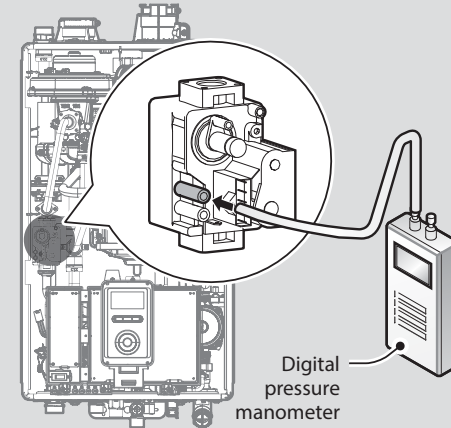

Figure 9. Connect Digital Pressure Monometer

b. Connect a manometer to the offset pressure port. For dual port manometers, use the positive pressure side.

Model	Kit Part No.	Gas Type	Offset
NCB-190/080H NCB-190/060H	NAC-NH190/080	NG	-0.01 in ± 0.01 in
	NAC-L190/080	LP	-0.04 in ± 0.01 in
NCB-240/130H NCB-240/110H	NAC-NH240/130	NG	-0.06 in ± 0.01 in
	NAC-L240/130	LP	-0.06 in ± 0.01 in
NCB-250/150H	NAC-NH250/150	NG	-0.06 in ± 0.01 in
	NAC-L250/150	LP	-0.06 in ± 0.01 in

Table 3. Offset value for low fire

c. Activate multiple zones and set the boiler to operate at 1-stage MIN mode. Measure the offset value at low fire and compare it to the values in Table 3. If the offset value is out of range, the gas valve set screw will need to be adjusted.

If adjustment is necessary, locate the set screw as shown in Figure 10. Using a ⁵/₃₂ in or 4mm Allen wrench, turn the set screw no more than ¹/₄ turn clockwise to raise or counterclockwise to lower the offset value.

5 7
6 8

! DANGER

- When conversion is required, be sure to set the PCB DIP switch 2 #1 according to the supply gas type.
- Note that the Gas Orifice from the LP CONVERSION KIT covers the boiler's installation at an altitude of 0 to 10,100 ft.
- Failure to properly set the DIP switches could cause carbon monoxide poisoning, resulting in severe personal injury or death.

11. Turn on the gas and water supply to the boiler.

12. Measure and adjust the gas/air ratio.

Option 1. Using Combustion Analyzer (recommended)

- Loosen the screw, rotate the plate and remove the gasket to access the emissions monitoring port as shown in Figure 7.
- Insert the analyzer into the port (Figure 7).

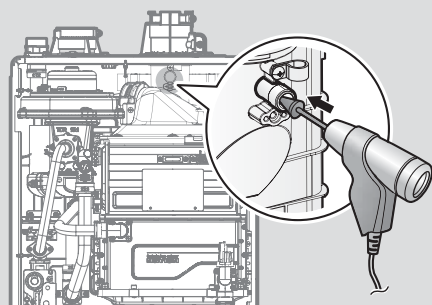

Figure 7. Insert the Analyzer

Model	Fuel	High fire	Low fire
		%CO ₂	%CO ₂
NCB-190/060H	NG	9.1	9.3
NCB-190/080H	LP	10.5	10.7
NCB-240/110H	NG	9.1	9.3
NCB-240/130H	LP	10.5	10.7
NCB-250/150H			

Table 2. CO₂ value
(CO₂ values must be within 0.5% of the values listed.)

c. Activate multiple zones and set the boiler to operate at 1-stage MIN mode. Measure the CO₂ value at low fire. If the CO₂ value is not within 0.5% of the value listed in Table 2, the gas valve set screw will need to be adjusted. If adjustment is necessary, locate the set screw as shown in Figure 8. Using a ⁵/₃₂ in or 4 mm Allen wrench, turn the set screw no more than ¹/₄ turn clockwise to raise or counterclockwise to lower the CO₂ value.

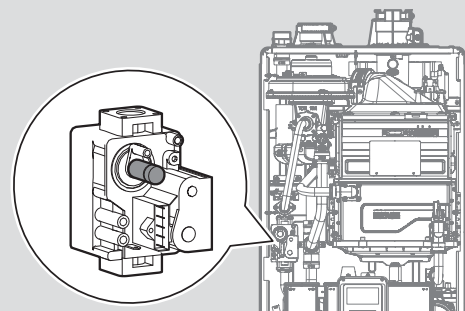

Figure 8. Set Screw Location

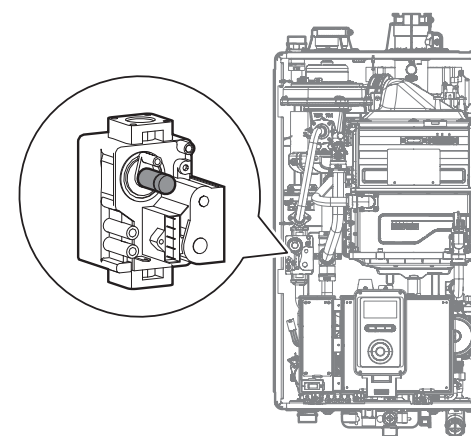

Figure 10. Set Screw Location

Note The set screw is located behind the screw-on cover. This must be removed first.

d. At high fire, do not check the offset value and never adjust the gas valve.

! DANGER

Improper gas valve settings can cause severe personal injury, death or substantial property damage.

13. Once the CO₂ or offset values have been confirmed, apply the included conversion stickers to show that the appliance has been converted to propane gas. Place these labels adjacent to the rating plate as shown in Figure 11.

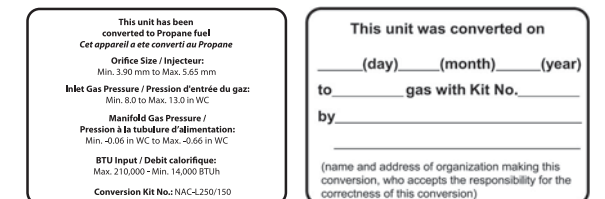

Figure 11. Proper Placement of Gas Conversion Labels

Note The gas conversion rating plate varies depending on the model. Check the conversion kit number before attaching the labels.



Navien, Inc.
20 Goodyear Irvine, CA 92618
TEL 1-800-519-8794 FAX 1-949-420-0430
www.NavienInc.com