

STEP 1 Before Installing

! Read the Installation & Operation Manual before installing.

This product must be installed and serviced by a licensed plumber, a licensed gas fitter, or a professional service technician. Navien is not liable for any damages or defects resulting from improper installation.



When applicable, the installation must conform with Manufactured Home Construction and Safety Standard, Title 24 CFR, Part 3280 and/or CAN/CSA Z240 MH Series, Mobile Homes.

! **WARNING**

Follow all local codes and/or the most recent edition of the National Fuel Gas Code (ANSI Z223.1/NFPA 54) in the USA, or the Natural Gas and Propane Installation Code in Canada (CAN/CGA B149.1).

Safety

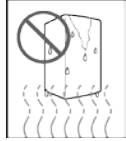

DO NOT install the boiler in areas with excessively high humidity.

Location Requirements

Select the best location on "Choosing an Installation" in the Installation & Operation Manual.

Allowable minimum clearances

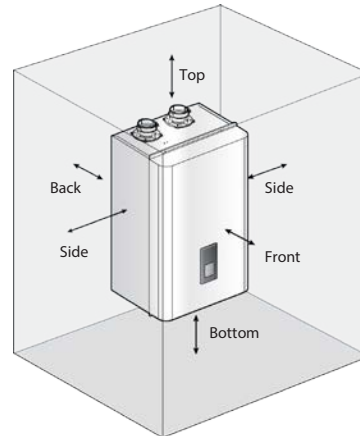

Clearance	Indoor Installation
Top	9 in (229 mm) minimum
Back	0.5 in (13 mm) minimum
Front	4 in (100 mm) minimum
Sides	3 in (76 mm) minimum
Bottom	12 in (300 mm) minimum

STEP 2 Installing

1 Unpacking



- Navien Combination Boiler
- User's Information Manual, Installation & Operation Manual
- Wall mounting bracket
- Tapping screws and anchors
- Vent terminators
- Wall flanges
- Conversion Kit
- Spare Parts
- Pressure Relief Valve (30PSI)
- Flow Restrictors

2 Checking the Rating Plate



This boiler is configured for Natural Gas from the factory. If conversion to Propane Gas is required, the conversion kit supplied with the boiler must be used.

! **WARNING**

- Before connecting the gas supply, determine the gas type and pressure for the boiler by referring to the rating plate. Use only the same gas type indicated on the rating plate. Using a different gas type will result in abnormal combustion and malfunction of the boiler. Gas supplies should be connected by a licensed professional only.
- The appliance and its gas connection must be leak tested before placing the appliance in operation.
- This boiler cannot be converted from natural gas to propane or vice versa without a Navien gas conversion kit. Do not attempt a field conversion of this boiler without a Navien gas conversion kit. Doing so will result in dangerous operating conditions and will void the warranty.

Navien America Inc. is not liable for any property damage and/or personal injury resulting from improper conversions.

3 Mounting on the Wall

! **CAUTION**

Do not install the boiler on dry walls without proper reinforcement.

- 1 Drill in the supplied anchor bolts after considering where the vent termination will be located.
- 2 Secure the mounting bracket to the wall with the tapping screws and anchors.
- 3 Lift up the boiler, rest the unit on the hooks provided on the wall bracket on the wall.

4 Removing the Front Cover

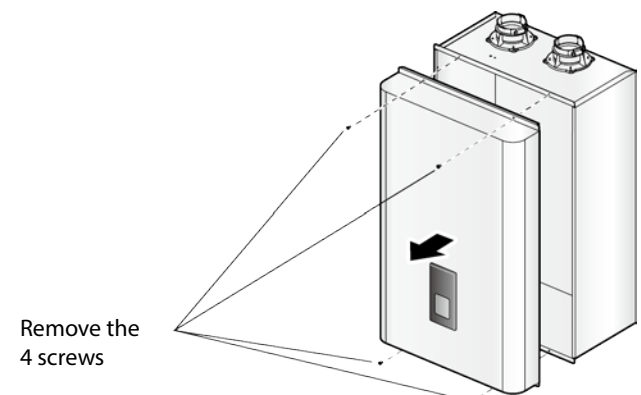

5 Gas Piping Connections

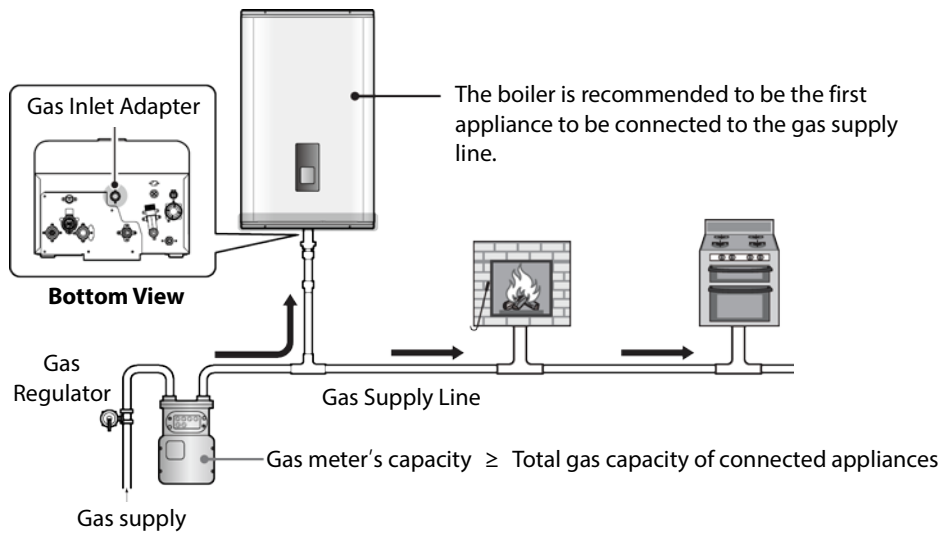

Example:

$$\text{Gas meter } \geq \text{Boiler } + \text{Furnace } + \text{Domestic gas stove}$$

$$425 \text{ CFH} \geq 195 \text{ CFH} + 58.8 \text{ CFH} + 63.7 \text{ CFH}$$

* 1 CFH=1,020 Btuh

- 1/2" rigid pipe can be used; refer to the sizing tables in the Installation & Operation Manual for limitations. Avoid using 1/2" corrugated connectors or tubing as noise may occur.

6 Water Piping Connections

Space Heating System

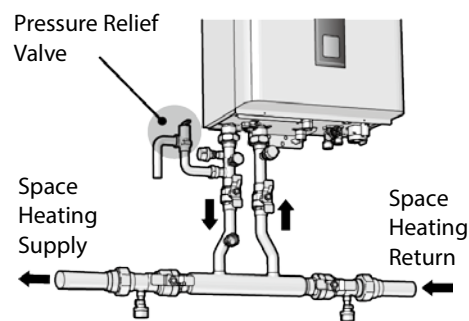

Install the included 3/4 in, maximum 30 psi pressure relief valve on the space heating supply.

An ASME approved HV pressure relief valve for space heating system is supplied with the boiler.

DHW System

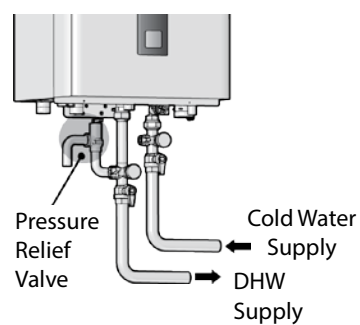

The DHW pressure relief valve is not supplied, but is required.

Install an approved 3/4 in, maximum 150 psi pressure relief valve on the hot water outlet.

Flow Restrictor (for DHW system)

The boiler has a built-in flow restrictor at the cold water inlet adapter to limit the overall DHW flow. Three additional flow restrictors are provided for different flow rates.



Flow Restrictors (Orange, Yellow, and Blue)

Refer to the following graph and install an appropriate restrictor for your DHW system. See the Installation & Operation Manual (page 21, 22) for detailed procedures.

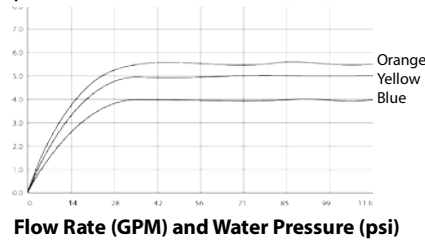

Water Piping Connections

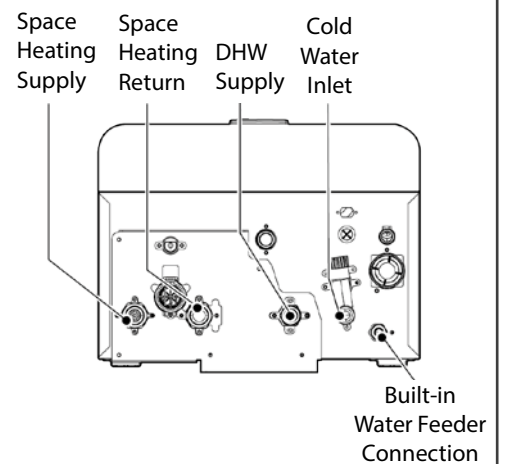

System Fill Connection

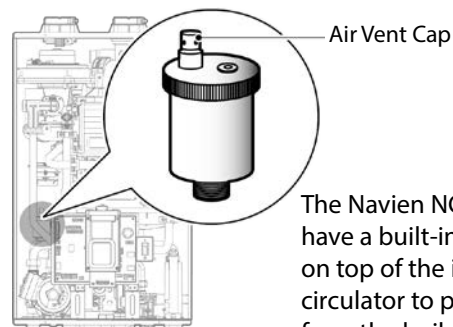

The Navien NCB boilers have a built-in air vent on top of the internal circulator to purge air from the boiler system.

Before filling the boiler, remove the air vent cap to allow the system to fill properly. Replace the cap when the system is full.

Warning Ensure that the Air Vent Cap is removed before filling the system. System will not be properly filled without the air vent cap removed. Air in the system may cause malfunctions and system overheating.

Built-in Water Fill Connection

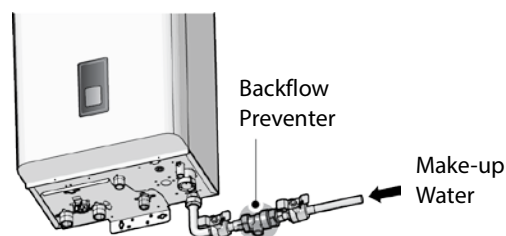

Note

Navien NCB boiler is equipped with an auto-feeding water connection and motorized feeding valve. Therefore, installation of additional system water fill connection is not necessary in most cases.

External Water Fill Connection

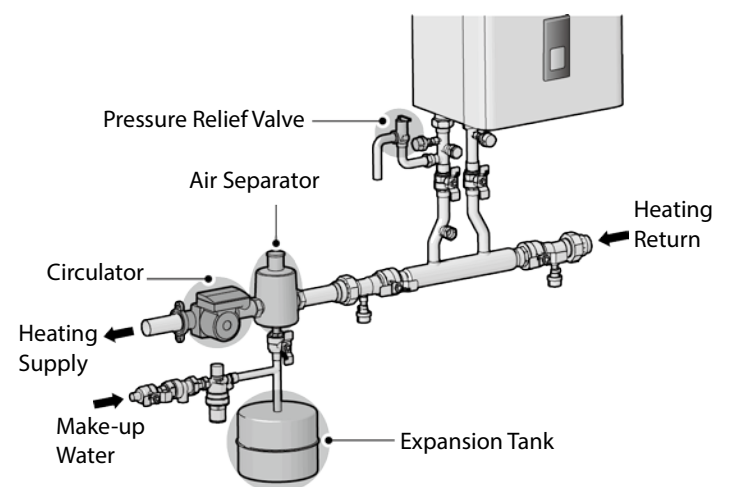

7 Condensate Drain Connection

A condensate drain pipe must be connected to the 1/2" condensate outlet fitting at the bottom of the unit and water must be poured into the exhaust connection to fill the condensate trap.

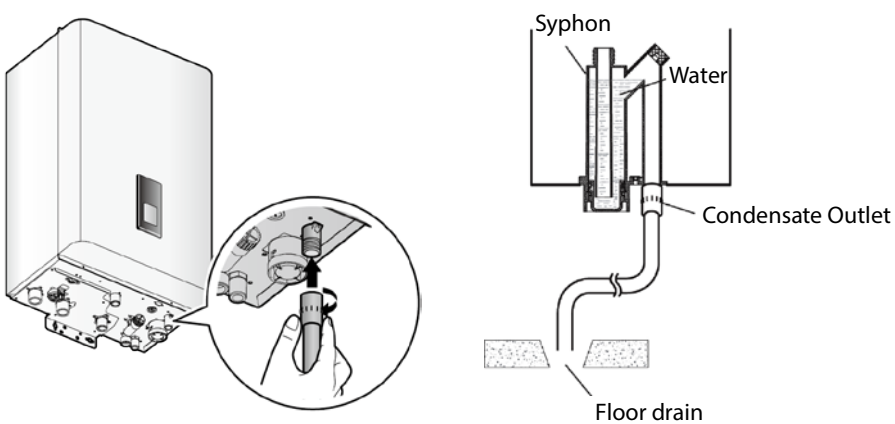

The end of the 1/2" (NPT) plastic piping should drain into a laundry tub or into a floor drain.

Note

Do not submerge the end of the pipe in water.

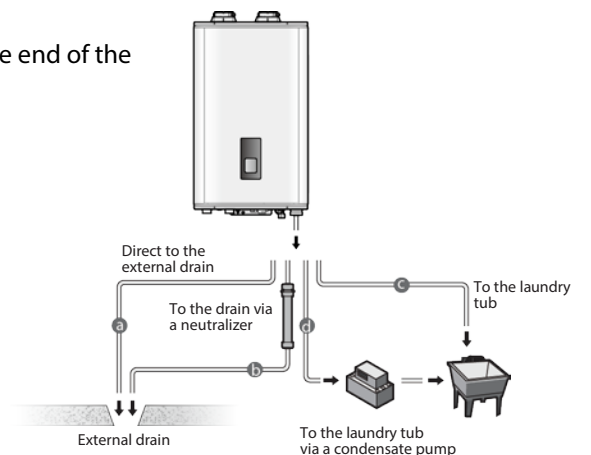

8 Venting

Vent Termination Options

Horizontal vent termination

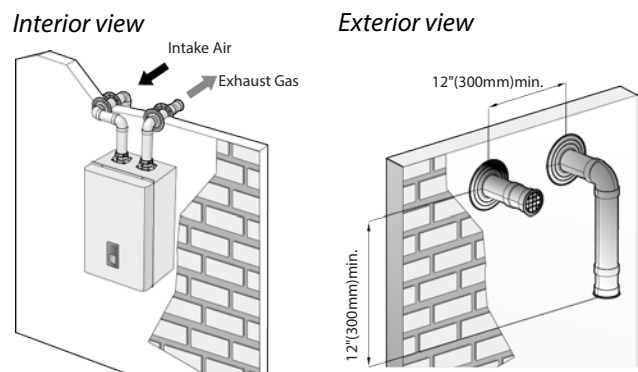

Vertical vent termination

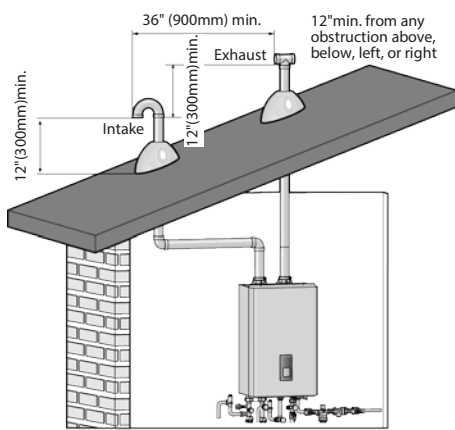

Sidewall vent termination

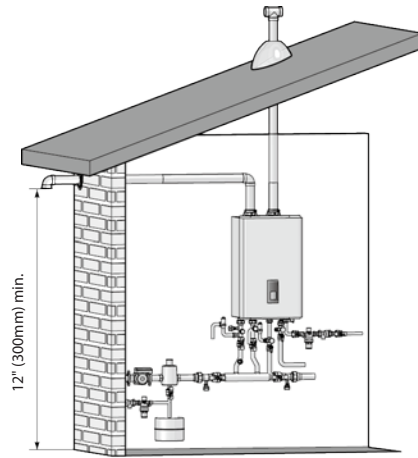

Concentric Vent Termination

Sidewall installation

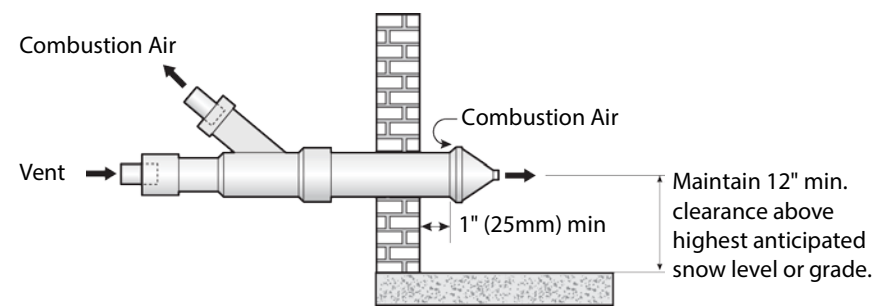

Roof installation

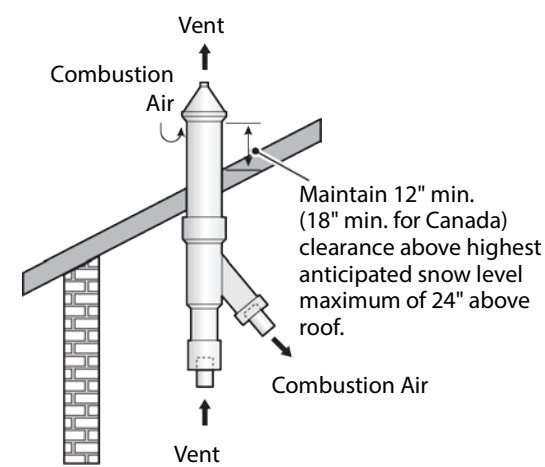

Venting Length

3" pipe venting

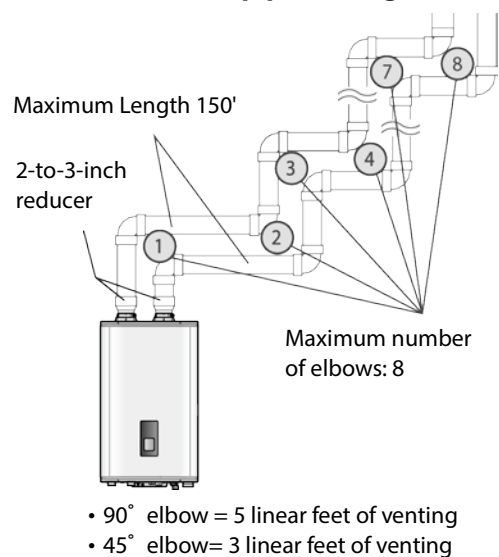

2" pipe venting

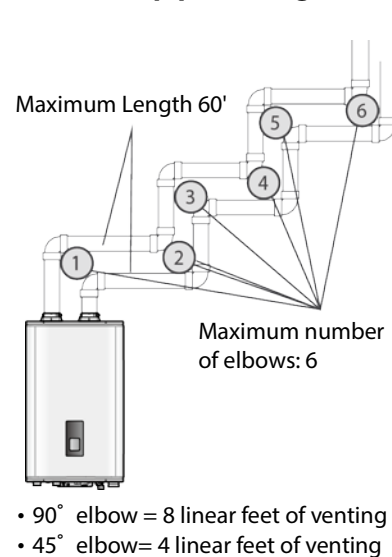

Exhaust Vent Piping Materials

- All Navien boilers are Category IV appliances.
- The venting system should be approved for use with Category IV appliances (typically Type BH Special Gas Vent approved by UL 1738-S636).
- Venting requirements in the USA and Canada are different (see below).

Navien recommended venting materials

Locale	Recommended Vent Materials
USA	<ul style="list-style-type: none"> • PVC Schedule 40(Solid core) • CPVC Schedule 40 or 80(Solid core) • Approved Polypropylene
Canada*	<ul style="list-style-type: none"> • Type BH Special Gas Vent Class IIA (PVC) • Type BH Special Gas Vent Class IIB (CPVC) • Type BH Special Gas Class IIC (Polypropylene)

* For installation in Canada, field-supplied plastic vent piping must comply with CAN/CGA B149.1 (latest edition) and be certified to the Standard For Type BH Gas Venting Systems, ULC-S636. Components of this listed system must not be interchanged with other vent systems or unlisted pipes or fittings. All plastic components and specified primers and glues of the certified vent system must be from a single system manufacturer and must not be intermixed with another system manufacturer's parts. The supplied vent connector and vent termination are certified as part of the boiler.

9 Electrical Connections

External LWCO Connection (if required by local codes)

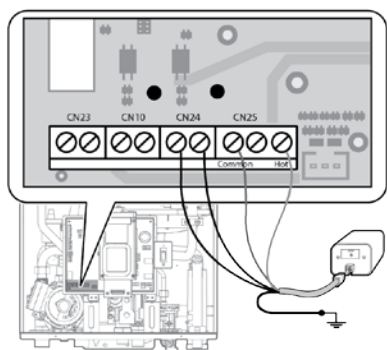

Refer to your local codes to determine if an LWCO device is required for your system and ensure that the built-in device meets the requirements.

Safety

CAUTION
Disconnect the power to the boiler before installing any wire connections on the main PCB.



DO NOT touch the power cord with wet hands.

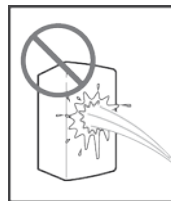

DO NOT allow the boiler to be exposed to excessive amounts of water.

Power Connection

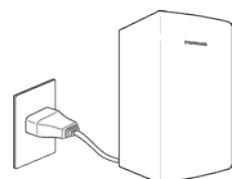

120 VAC 60 Hz
Min. 2 Amp current with proper grounding

CAUTION
Using abnormally high or low AC voltage may cause abnormal operation, thereby causing fire which reduces the life expectancy of this product.

Confirmation of Panel DIP Switch Settings

PCB Dip Switch 2 (Set of 8)

SW	Function	Setting
1	Temperature Control	Return Water 1-ON
		Supply Water 1-OFF
7	Thermostat or Zone Controller	Unused (Permanent Space Heating Demand) 7-ON
		Used 7-OFF
8	Exhaust Thermostat	Temperature Limit Unused (CPVC) 8-ON
		Setting (PVC) 8-OFF

Front Panel Dip Switch 1 (Set of 10)

SW	Function	Setting
2	Temperature Unit	°C (Celsius) 2-ON
		°F (Fahrenheit) 2-OFF
3	Well Pump	On 3-ON
		Off 3-OFF
4 & 5	High Altitude*	0-1,999 ft (0-609 m) 4-OFF, 5-OFF
		2,000-5,399 ft (610-1,645 m) 4-ON, 5-OFF
		5,400-7,699 ft (1,646-2,346 m) 4-OFF, 5-ON
		7,700-10,100 ft (2,347-3,078 m) 4-ON, 5-ON

* Above 2,000 ft (610 m), the boiler will derate by 4% for each 1,000 ft (305 m) of altitude gain.

Front Panel Dip Switch 2 (Set of 2)

SW	Function	Setting
2	Gas Type	Natural Gas 2-OFF
		Propane Gas 2-ON

STEP 3 After Installing

1 Opening All the Valves

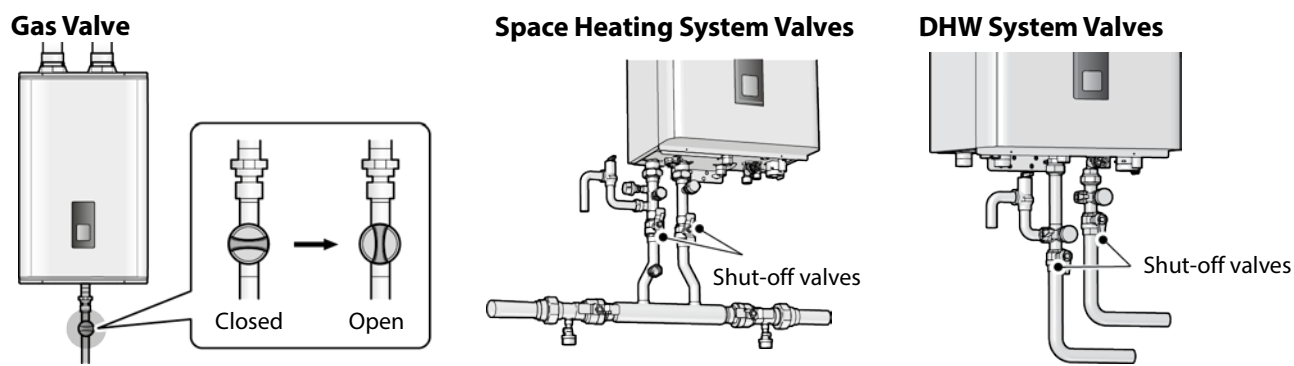

Navien
 Navien America, Inc.
 20 Goodyear, Irvine, CA 92618
 Tel: (949) 420-0420, Fax: (949) 420-0430
 www.navienamerica.com

2 Operating the Boiler

Power ON	Adjust Temperatures	View Basic Information	Resetting the Boiler
<p>When the power is on, the water temperature of the space heating supply will appear with the water pressure on the front panel display in 5 second intervals.</p>	<p>Space Heating Temperature</p> <ol style="list-style-type: none"> 1. Press the Mode button once. The space heating icon turns on. 2. Press the + (Up) or - (Down) buttons until the desired temperature appears on the display. 	<p>DHW Temperature</p> <ol style="list-style-type: none"> 1. Make sure that all hot water faucets are closed, and ensure that the internal circulator and any external circulating pumps are off. 2. Press the Mode button twice. The DHW mode icon turns on. 3. Press + (Up) or - (Down) buttons until the desired temperature appears on the display. <p>Note DHW temperature higher than 125°F can cause scalding.</p>	<ol style="list-style-type: none"> 1. Press the Mode button three times. "INFO" will appear on the display. 2. Press the + or - buttons to switch between the information types. <p>Note If an error message appears, you can try resetting the boiler to resolve the problem.</p> <p>Note If resetting does not solve the problem, refer to the troubleshooting section of the User's Information Manual or contact the service center.</p>

3 Measuring the Inlet Gas Pressure

- Shut off the manual gas valve.
- Open a hot water faucet. The boiler should turn on and the gas in the gas supply line will be purged.

Leave the faucet on until the boiler shuts down due to a lack of gas supply, and then turn off the hot water faucet.
- Remove the front cover by loosening the 4 screws.
- Loosen the screw indicated in the figure and connect a manometer to the pressure port. Reset the manometer to zero before use.
- Recommended Gas Pressure Settings:**

NG : 3.5"~10.5" WC
 LP : 8.0"~13.5" WC
- Check the inlet gas pressure reading on the manometer.
- If not, Adjust the inlet gas pressure with gas regulator.
- Re-open the manual gas valve and check for leaks.

Open multiple fixtures that have high flow rates, such as bathtub and shower faucets, to ramp the boiler up to its maximum firing rate.

CAUTION
 The boiler cannot function properly without sufficient inlet gas pressure.
Measuring the inlet gas pressure should be performed by a licensed professional only.

4 Installing the Front Cover

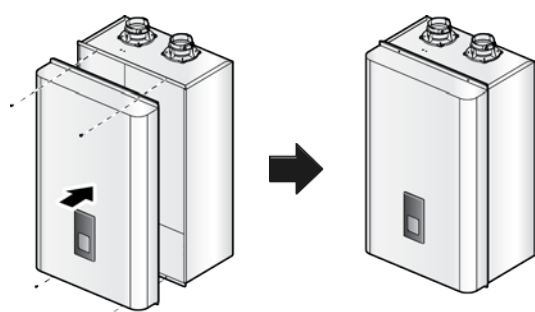

5 Ensure Maximum Water Flow

After running the boiler for the first 10 minutes, turn it off and clean the cold water filter and the space heating return strainer to remove any trapped debris.

6 Final Check

A trial run should be performed in accordance with the Installation checklist listed in the boiler's Installation & Operation Manual.