



Navien
Condensing Boilers

High Altitude Conversion Guide (Altitude : 5,400~10,100ft)

Make sure to use the proper high altitude conversion kit for Natural Gas or Propane.

Model

NFB-301C
NFB-399C

This boiler is configured for Natural Gas at the factory.

- If conversion to Propane Gas is required by the boiler, use the LP CONVERSION KIT supplied with the boiler.
- If the boiler is installed at a high altitude above 5,400ft, use the HIGH ALTITUDE CONVERSION KIT supplied with the boiler.

WARNING

This conversion kit must be installed by a qualified service agency* in accordance with Navien's instructions and all applicable codes and requirements of the authority having jurisdiction. The information in these instructions must be followed to minimize the risk of fire or explosion or to prevent property damage, personal injury or death. The qualified service agency is responsible for the proper installation of this kit. The installation is not proper and complete until the operation of the converted appliance is checked as specified in the manufacturer's instructions supplied with the kit.

* A qualified service agency is any individual, firm, corporation or company which either in person or through a representative is engaged in and is responsible for the connection, utilization, repair or servicing of gas utilization equipment or accessories; who is experienced in such work, familiar with all precautions required, and has complied with all of the requirements of the authority having jurisdiction.

In Canada: The conversion shall be carried out in accordance with the requirements of the provincial authorities having jurisdiction and in accordance with the requirements of the CAN-B149.1 and CAN1-B149.2 Installation Code.

Tools Required:

- Phillips Screwdriver
- Flathead Screwdriver
- ⁵/₃₂ in or 4 mm Allen Wrench
- T40 or 6.65 mm Star Wrench
- Combustion Analyzer or Dual Port Manometer
- Gas Leak Detector

Included Items:

- Gas Orifice (Table 1)
- Gas Pressure and Conversion Kit Number Labels

3. Remove the front cover and place it in a safe location to prevent accidental damage.
4. With the internal components exposed, locate the gas inlet pipe and the gas valve, as shown in Figure 2.

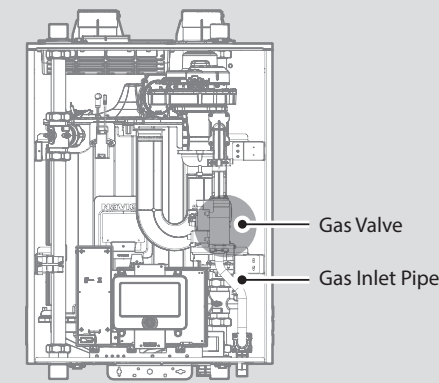

Figure 2. NFB Series Internal Components

5. Remove the clip at location A – the connection above the gas valve where it connects to the gas valve outlet adapter. See Figure 3 for reference.
6. Find location B - the connection above the gas valve where it is attached to the fan motor assembly. Carefully remove the four screws using a Phillips-head screwdriver and pull the gas valve outlet adapter away from the fan assembly to access the Gas Orifice.

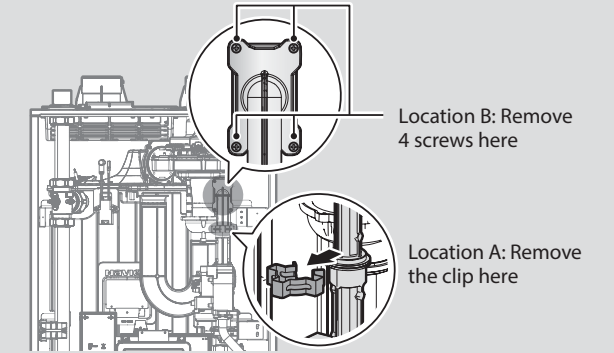

Figure 3. Detaching the Gas Valve Outlet Adapter from the Gas Valve and Fan Motor Assembly

7. Once the Gas Orifice is exposed, remove the four screws that hold the part in place. Remove the Gas Orifice from its housing and prepare the new Gas Orifice for the high altitude conversion for installation.

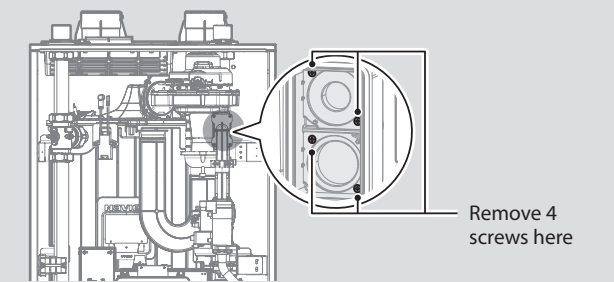

Figure 4. Access to Gas Orifice in Fan Assembly

1 3
2 4

NFB-301C Orifice Identification

Gas Type	NG		LP		
	Altitude	0-5,399 ft	5,400-10,100 ft	0-5,399 ft	5,400-10,100 ft
Orifice					
		Factory Installed	For High Altitude	For Sea Level	For High Altitude
Orifice Size		Ø6.75 / Ø9.25	Ø7.40 / Ø9.60	Ø5.40 / Ø6.75	Ø5.40 / Ø6.65

NFB-399C Orifice Identification

Gas Type	NG		LP		
	Altitude	0-5,399 ft	5,400-10,100 ft	0-5,399 ft	5,400-10,100 ft
Orifice					
		Factory Installed	For High Altitude	For Sea Level	For High Altitude
Orifice Size		Ø8.35 / Ø15.1	Ø8.65 / Ø17.0	Ø6.55 / Ø9.50	Ø6.55 / Ø9.30

Table 1. Orifice Size

WARNING

- NG and LP high altitude conversion kits and a LP conversion kit are provided with the boiler. Be careful not to confuse the LP conversion kit and LP high altitude conversion kit.
- Make sure that connections are made with the proper orifice. If the installed orifice does not conform to the specifications in Table 1, incomplete combustion may occur, resulting in personal injury or property damage.

Procedure:

1. Turn off both gas and water supply to the boiler.
2. Unfasten the 4 latches (2 at the top and 2 at the bottom) to remove the front cover and gain access to the internal components. See Figure 1 for illustration of the front cover clamps.

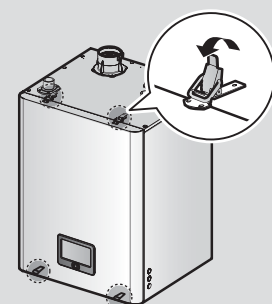

Figure 1. NFB Series Front cover

WARNING

- DO NOT adjust or attempt to measure gas valve outlet pressure. The gas valve is factory-set for the correct outlet pressure. This setting is suitable for natural gas and propane, requiring no field adjustment.
- Attempting to alter or measure the gas valve outlet pressure could result in damage to the valve, causing potential severe personal injury, death or substantial property damage. Navien NFB boilers are shipped ready to fire natural gas ONLY.

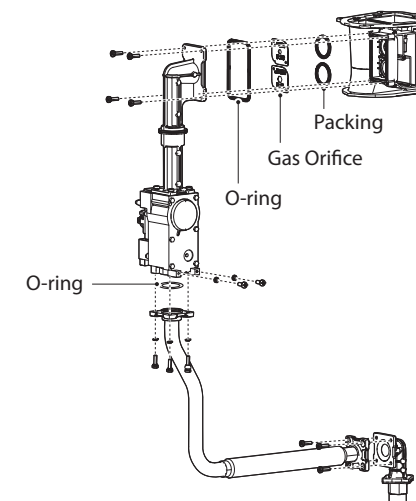
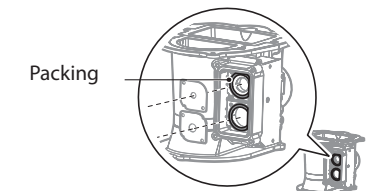

Figure 5. Exploded View of Gas Pipe Assembly

DANGER

See Figure 5. Inspect the O-ring between the gas valve and gas valve inlet adapter whenever they are disassembled. The O-ring must be in good condition and must be installed. Failure to comply will cause a gas leak, resulting in severe personal injury or death.

8. Remove the Gas Orifice, ensure that the packing is properly seated inside the port, and then install the new Gas Orifice for use at high altitudes. Ensure that the Orifice is properly seated on the packing inside the port before proceeding to the next step.



9. Replace the gas inlet pipe to its original position and use all screws to secure all connections.

Note Do not overtighten as this may damage or crack the components.

DANGER

Inspect the O-ring between the gas valve and gas valve inlet adapter whenever they are disassembled. The O-ring must be in good condition and must be installed. Failure to comply will cause a gas leak, resulting in severe personal injury or death.

10. Set the PCB DIP switch to change the gas type. For LP, set DIP switch 2 #1 to ON. For NG, set DIP SW2 #1 to OFF.

WARNING

Ensure that you have turned off the power to the boiler before accessing the DIP switches.

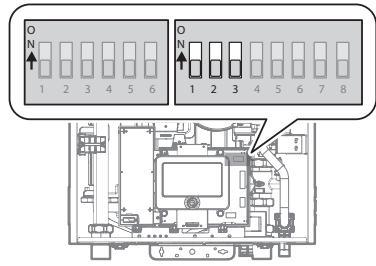

Switch	Function	Setting	Comment
1	Gas Type	Natural Gas	1-OFF
		Propane Gas	1-ON
2&3	High Altitude	0-1,999 ft (0-609 m)	2-OFF, 3-OFF
		2,000-5,399 ft (610-1,645 m)	2-ON, 3-OFF
		5,400-7,699 ft (1,646-2,346 m)	2-OFF, 3-ON
		7,700-10,100 ft (2,347-3,078 m)	2-ON, 3-ON

Refer to Table 1 on page 2.

WARNING

When applying the Gas Orifice for high altitude, set the PCB DIP switches by altitude according to the table above.

- Note**
- This unit may be installed at elevations up to 10,100 ft (3,078 m) for use with natural gas and propane. To use the unit at a specific altitude, the DIP switch should be set as described above.
 - In high altitudes above 2,000 ft (610 m), the unit will derate by 3% for each 1,000 ft (305 m) of altitude gain.
 - If you install the unit at above 5,400 ft (1,646 m) it is required to change the Gas Orifice for high altitude.
 - NG and LP high altitude conversion kits and a LP conversion kit are provided with the boiler. Be careful not to confuse the LP conversion kit and LP high altitude conversion kit.

DANGER

- When conversion is required, be sure to set the PCB DIP switch 2 #1 according to the supply gas type.
- NG and LP high altitude conversion kits and a LP conversion kit are provided with the boiler. Be careful not to confuse the LP conversion kit and LP high altitude conversion kit.
- For high altitude conversion, check the DIP switches setting value by altitude before setting.
- Failure to properly set the DIP switches could cause carbon monoxide poisoning, resulting in severe personal injury or death.

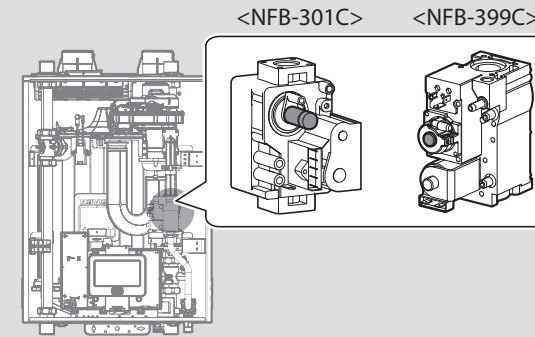

Figure 7. Set Screw Location

Note The set screw is located behind the screw-on cover. This must be removed first.

- d. Activate multiple zones and set the boiler to operate at 2Step MAX mode (refer to "11.4.7 Setting the Operation Modes" in the Installation & Operation Manual). Measure the CO₂ value at high fire. If the CO₂ values do not match Table 2 at high fire, do not adjust the gas valve. Check for the proper Gas Orifice.

DANGER

Improper gas valve settings can cause severe personal injury, death or substantial property damage.

Option 2. Using Digital Manometer

- a. Open the offset pressure port by loosening the screw two turns as shown in Figure 8.

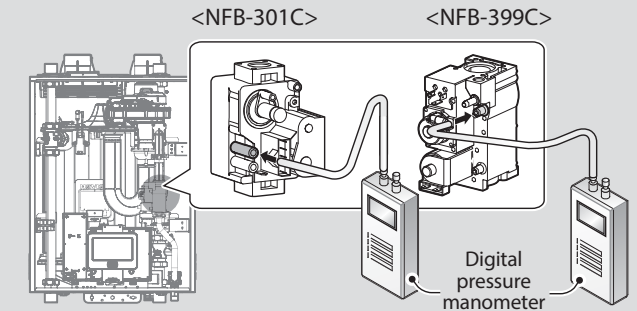

Figure 8. Connect Digital Pressure Manometer

- b. Connect a manometer to the offset pressure port. For dual port manometers, use the positive pressure side.

Model	Kit Part No.	Gas Type	Offset
NFB-301C	NAC-NH301	NG	-0.06in ± 0.01in
	NAC-LH301	LP	-0.01in ± 0.01in
NFB-399C	NAC-NH399	NG	-0.03in ± 0.01in
	NAC-LH399	LP	-0.01in ± 0.01in

Table 3. Offset value for low fire

11. Turn on the gas and water supply to the boiler.

CAUTION

Ensure that the High Altitude setting reflect the actual location of the boiler. If not it may cause personal injury or malfunction of the boiler.

12. Measure and adjust the gas/air ratio.

Option 1. Using Combustion Analyzer (recommended)

- Loosen the screw, rotate the plate and remove the gasket to access the emissions monitoring port as shown in Figure 6.
- Insert the analyzer into the port (Figure 6).

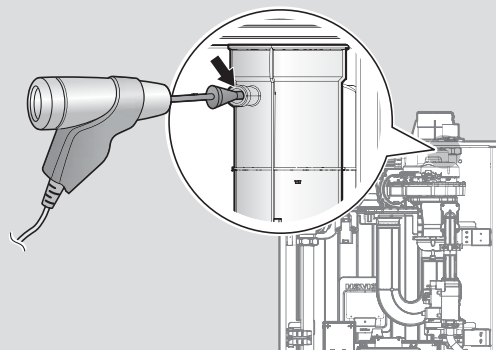

Figure 6. Insert the Analyzer

Model	Altitude	Fuel	High fire	Low fire
			%CO ₂	%CO ₂
NFB-301C	0-5,399 ft	NG	9.2	8.9
		LP	10.8	10.7
	5,400-10,100 ft	NG	8.8	9.0
		LP	9.9	11.0

Model	Altitude	Fuel	High fire	Low fire
			%CO ₂	%CO ₂
NFB-399C	0-5,399 ft	NG	9.4	8.9
		LP	10.6	10.4
	5,400-10,100 ft	NG	8.8	9.0
		LP	9.9	11.0

Table 2. CO₂ value (CO₂ values must be within 0.5% of the values listed.)

- c. Activate multiple zones and set the boiler to operate at 1Step MIN mode. Measure the CO₂ value at low fire. If the CO₂ value is not within 0.5% of the value listed in Table 2, the gas valve set screw will need to be adjusted. If adjustment is necessary, locate the set screw as shown in Figure 7. Using a Allen or Star Wrench, turn the set screw no more than 1/4 turn clockwise to raise or counterclockwise to lower the CO₂ value.

5 7
6 8

- c. Activate multiple zones and set the boiler to operate at 1Step MIN mode (refer to "11.4.7 Setting the Operation Modes" in the Installation & Operation Manual). Measure the offset value at low fire and compare it to the values in Table 3. If the offset value is out of range, the gas valve set screw will need to be adjusted. If adjustment is necessary, locate the set screw as shown in Figure 9. Using an Allen or Star Wrench, turn the set screw no more than 1/4 turn clockwise to raise or counterclockwise to lower the offset value.

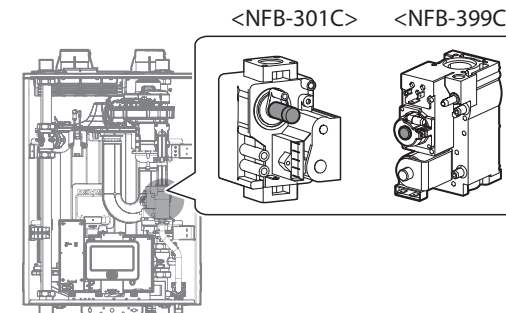

Figure 9. Set Screw Location

Note The set screw is located behind the screw-on cover. This must be removed first.

- d. At high fire, do not check the offset value and never adjust the gas valve.

DANGER

Improper gas valve settings can cause severe personal injury, death or substantial property damage.

13. Once the CO₂ or offset values have been confirmed, apply the included conversion stickers to show that the appliance has been converted to propane gas or high altitude. Place these labels adjacent to the rating plate as shown in Figure 10.

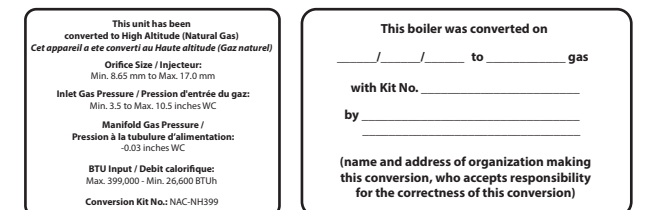

Figure 10. Proper Placement of Gas Conversion Labels

Navien

Navien, Inc.
20 Goodyear Irvine, CA 92618
TEL 1-800-519-8794 FAX 1-949-420-0430
www.navien.com