



28885049

STEP 1 Before Installing

Read the Installation & Operation Manual before installing.

This product must be installed and serviced by a licensed plumber, a licensed gas fitter, or a professional service technician. Navien is not liable for any damages or defects resulting from improper installation.

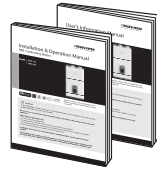

WARNING

Follow all local codes and/or the most recent edition of the National Fuel Gas Code (ANSI Z223.1/NFPA 54) in the USA, or the Natural Gas and Propane Installation Code in Canada (CAN/CGA B149.1).

Safety

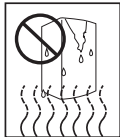

DO NOT install the boiler in areas with excessively high humidity.

STEP 2 Installing

1 Unpacking

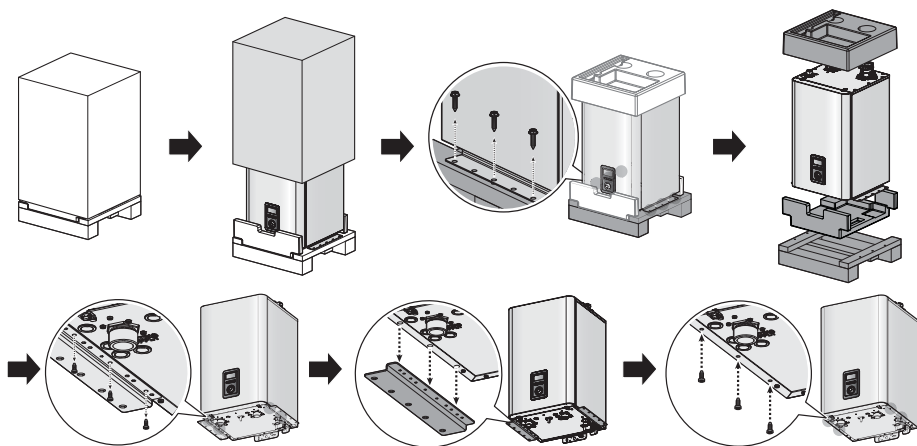

2 Checking the Rating Plate

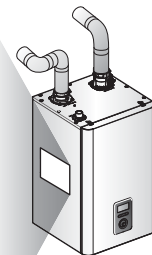
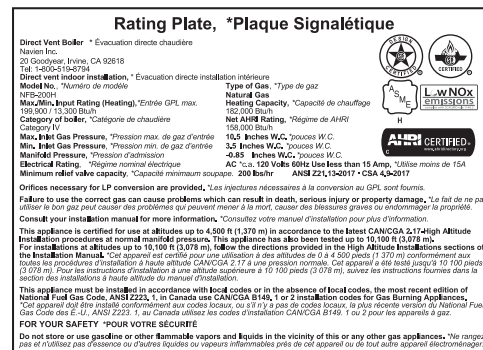

This boiler is configured for Natural Gas from the factory. If conversion to Propane Gas is required, the Propane Conversion Kit supplied with the boiler must be used.

	Navien Condensing Boiler		User's Information Manual, Installation & Operation Manual		Quick Installation Manual
	Air Vent		High Altitude Conversion Kit (Natural Gas Only)*		Propane Conversion Kit*
	Tapping screws and anchors		Pressure Relief Valve, Heating		2 in Vent Termination Caps
	Air Vent Bushing (3/4 in to 1/2 in)		Outdoor Temperature Sensor and Cable		Condensate Trap
	Wall Flanges		Wall Mounting Bracket		Universal Temperature Sensor
	Spare Parts	*High Altitude Conversion kit and Propane Conversion kit are attached to the inside of Product's cover.			

WARNING

- Before connecting the gas supply, determine the gas type and pressure for the boiler by referring to the rating plate. Use only the same gas type indicated on the rating plate. Using a different gas type will result in abnormal combustion and malfunction of the boiler. Gas supplies should be connected by a licensed professional only.
 - The appliance and its gas connection must be leak tested before placing the appliance in operation.
 - This boiler cannot be converted from natural gas to propane or vice versa without a Navien gas conversion kit. Doing so will result in dangerous operating conditions and will void the warranty.
- Navien Inc. is not liable for any property damage and/or personal injury resulting from improper conversions.**

3 Mounting on the Wall

CAUTION

Do not install the boiler on dry walls without proper reinforcement.

1 Drill in the supplied anchor bolts after considering where the vent termination will be located.

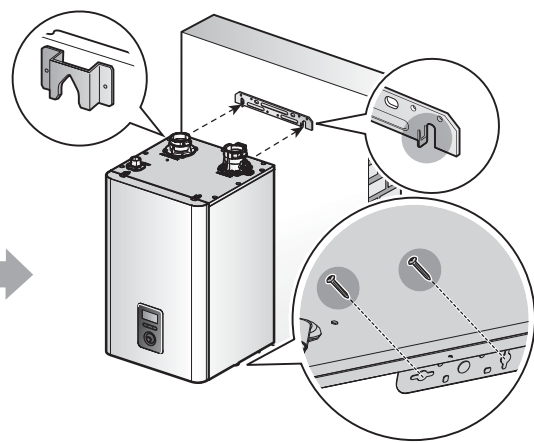
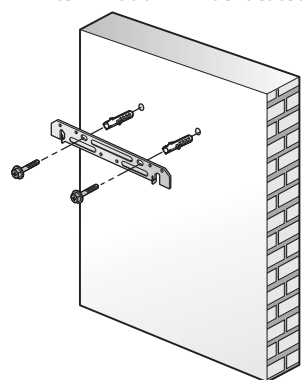

2 Secure the mounting bracket to the wall with the tapping screws and anchors.

Lift up the boiler, rest the unit on the hooks provided on the wall bracket on the wall.

4 Removing the Front Cover

Unclasp the 4 buckles that fix the cover to the boiler, and then remove the cover by lifting it and pulling it outward

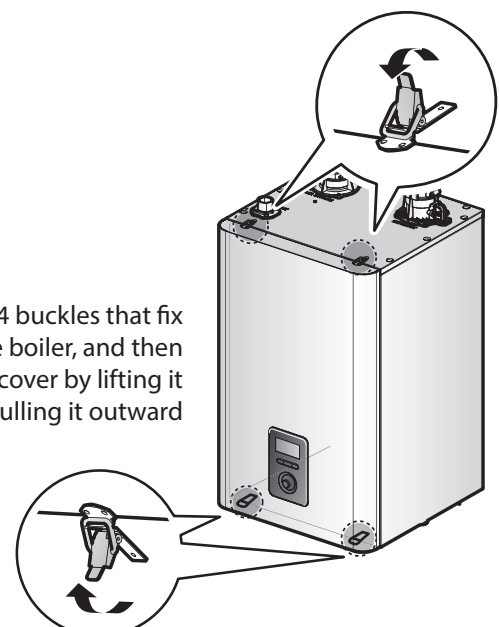

5 Gas Piping Connections

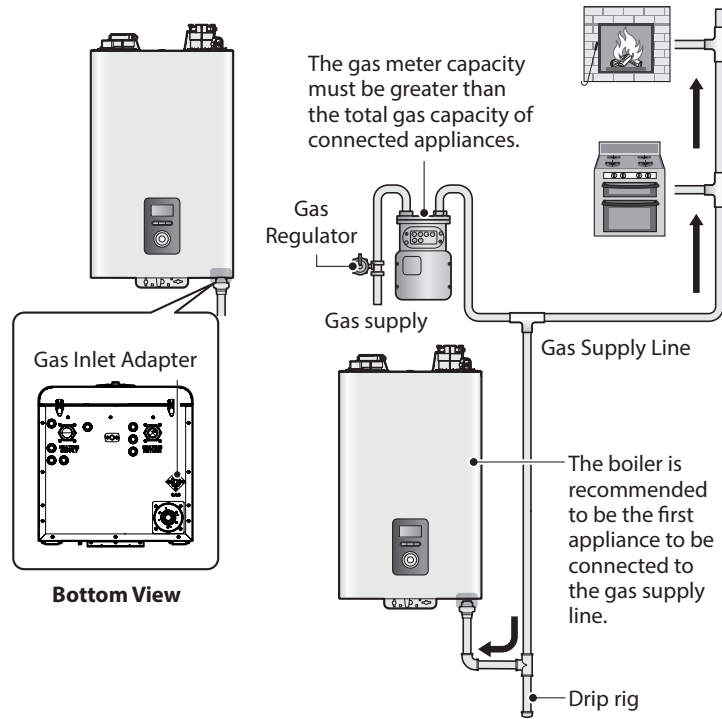

Example:

$$\text{Gas meter } 425 \text{ CFH} \geq \text{Boiler } 195 \text{ CFH} + \text{Furnace } 58.8 \text{ CFH} + \text{Domestic gas stove } 63.7 \text{ CFH}$$

* 1 CFH=1,020 Btuh

1/2" rigid pipe can be used; refer to the sizing tables in the Installation & Operation Manual for limitations. Avoid using 1/2" corrugated connectors or tubing as noise may occur.

6 Water Piping Connections

Space Heating System

A pressure relief valve must be installed when installing pipings for a heating system.

Install the included 3/4 in, maximum 30 psi pressure relief valve on the space heating supply.

An ASME approved HV pressure relief valve for space heating system is supplied with the boiler.

You may install the pressure relief valve on the space heating supply of the Navien Manifold System, or on the top connection along with the air vent (and an external LWCO, if required).

CAUTION

Do not solder piping directly onto the water connections, as the heat may cause damage to internal components. Use threaded water connections only.

Note

Prior to connecting plumbing to the boiler, flush the entire system to ensure it is free of sediment, flux, scale, debris or other impurities that may be harmful to the system and boiler. During the assembly of the heating system, it is important to keep the inside of the piping free of any debris including construction dust, copper burr, sand and dirt.

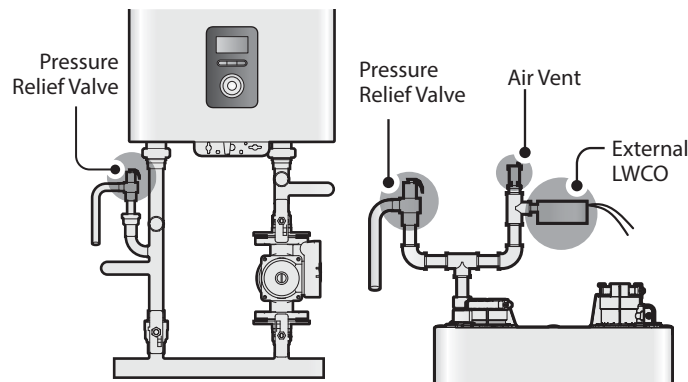

Water Piping Connections

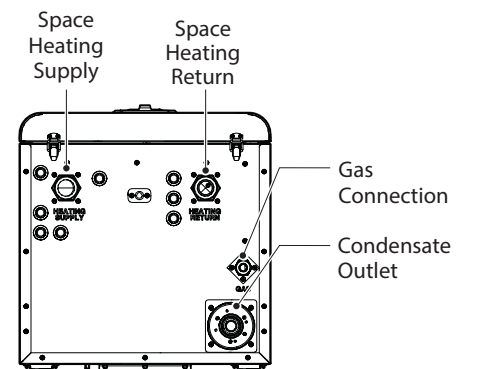

System Fill Connection

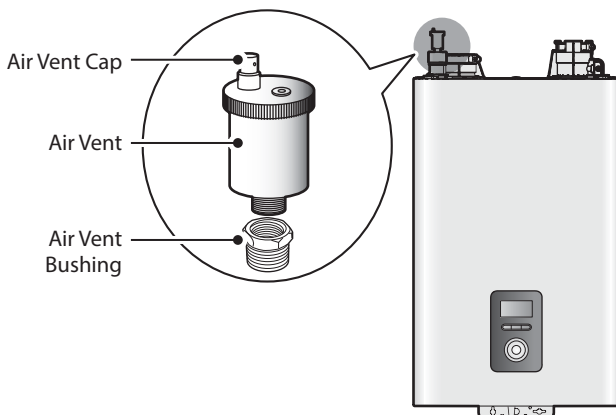

The Navien NFB-H boilers have a top connection for an air vent. An air vent must be installed to purge air from the boiler system.

When installing the air vent, install the air vent bushing between the air vent and the top connection.

Before filling the boiler, remove the air vent cap to allow the system to fill properly. Replace the cap when the system is full.

Note

Ensure that the vent cap is re-installed and the vent screws on the system and boiler pumps are properly tightened before testing or operating the system.

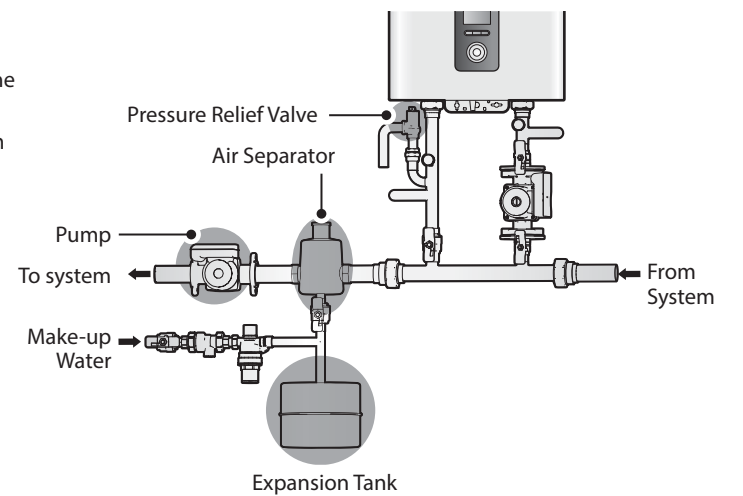

7 Condensate Drain Connection

A condensate drain pipe must be connected to the 1/2" condensate trap fitting at the bottom of the unit and water must be poured into the exhaust connection to fill the condensate trap.

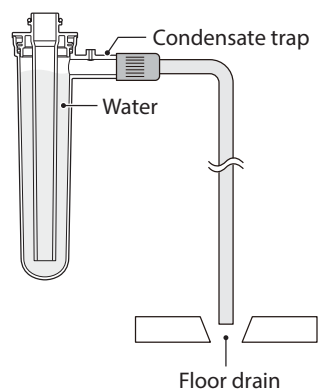
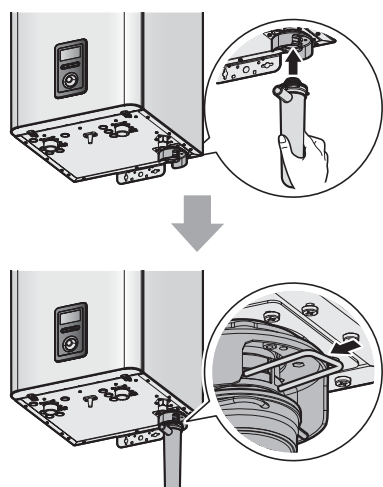

The end of the 1/2" (NPT) plastic piping should drain into a laundry tub or into a floor drain.

Note

Do not submerge the end of the pipe in water.

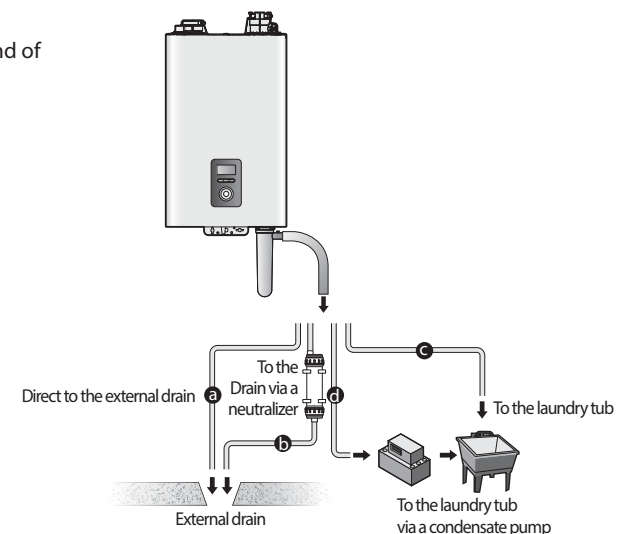

8 Venting

Vent Termination Options

Horizontal vent termination

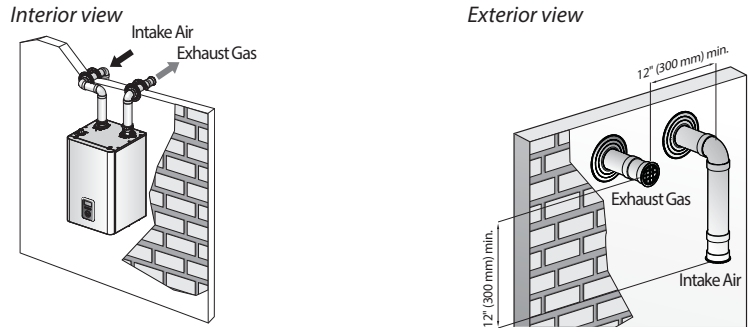

Vertical vent termination

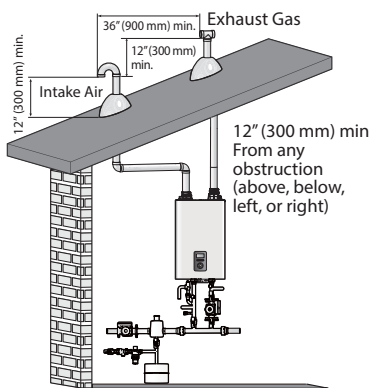

Sidewall vent termination

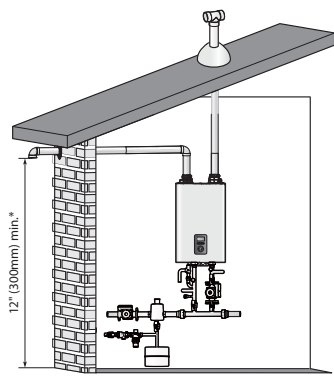

Concentric Vent Termination

Sidewall installation

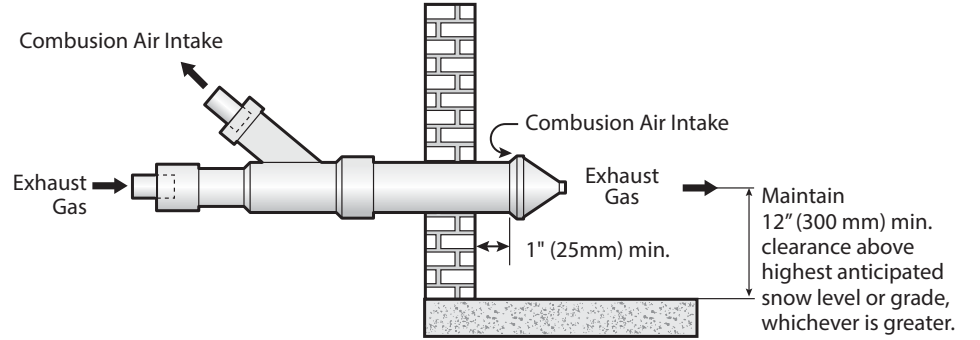

Roof installation

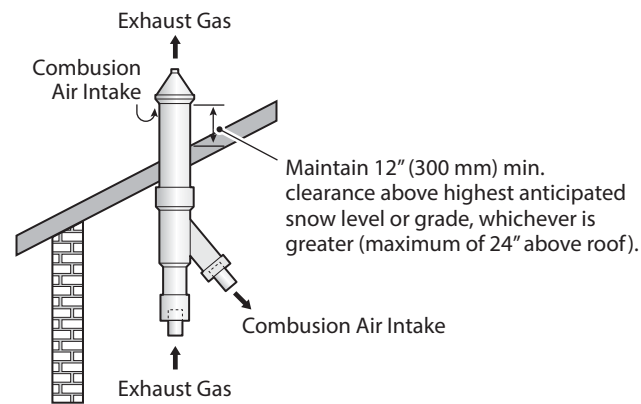

Venting Length

3" pipe venting

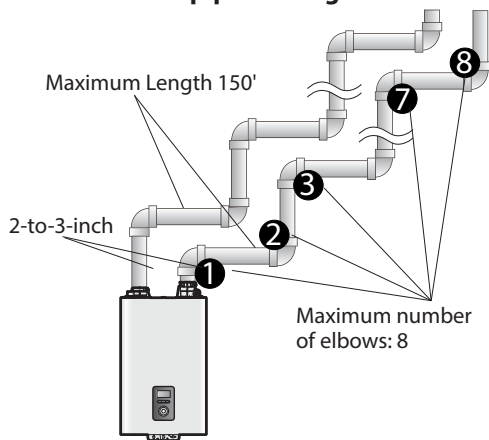

- 90° elbow = 5 linear feet of venting
- 45° elbow = 3 linear feet of venting

2" pipe venting

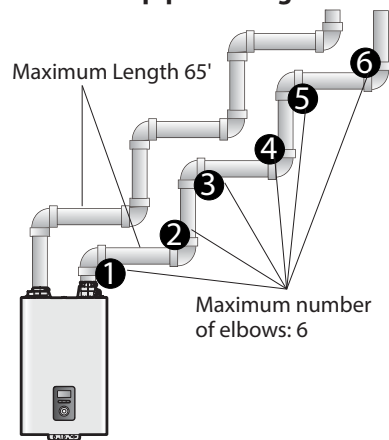

- 90° elbow = 8 linear feet of venting
- 45° elbow = 4 linear feet of venting

Exhaust Vent Piping Materials

- All Navien boilers are Category IV appliances.
- The venting system should be approved for use with Category IV appliances (typically Type BH Special Gas Vent approved by UL 1738-S636).
- Venting requirements in the USA and Canada are different (see below).

Navien recommended venting materials

Locale	Recommended Vent Materials
USA	<ul style="list-style-type: none"> • PVC/CPVC Schedule 40 or 80 (Solid Core) • UL1738 approved PVC or CPVC • Approved Polypropylene (PP) • Approved Stainless Steel (SS)
Canada*	<ul style="list-style-type: none"> • Type BH Special Gas Vent Class IIA (PVC) • Type BH Special Gas Vent Class IIB (CPVC) • Type BH Special Gas Vent Class IIC (Polypropylene/Stainless Steel)

* For installation in Canada, field-supplied plastic vent piping must comply with CAN/CGA B149.1 (latest edition) and be certified to the Standard For Type BH Gas Venting Systems, ULC-S636. Components of this listed system must not be interchanged with other vent systems or unlisted pipes or fittings. All plastic components and specified primers and glues of the certified vent system must be from a single system manufacturer and must not be intermixed with another system manufacturer's parts. The supplied vent connector and vent termination are certified as part of the boiler.

9 Electrical Connections/High Altitude DIP Switch Settings

External LWCO Connection (if required by local codes)

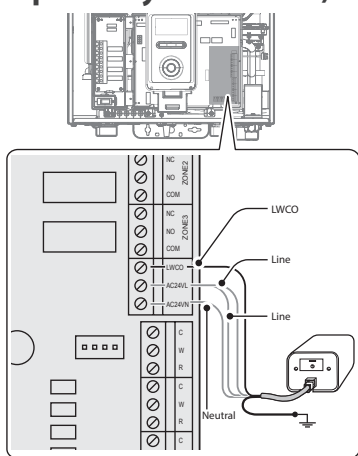

Refer to your local codes to determine if an LWCO device is required for your system and ensure that the built-in device meets the requirements.

CAUTION

Disconnect the power to the boiler before installing any wire connections on the main PCB.

Safety



DO NOT touch the power cord with wet hands.



DO NOT allow the boiler to be exposed to excessive amounts of water.

Power Connection

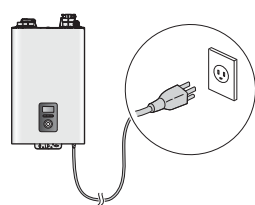

120 V AC 60 Hz
Min. 2 Amp current with proper grounding

CAUTION

Using abnormally high or low AC voltage may cause abnormal operation, thereby causing fire which reduces the life expectancy of this product.

Confirmation of DIP switch Settings/High Altitude DIP Switch Settings

DIP Switch 1 (Set of 6 Switches)

SW	Function	Setting	Comment
4	Reserved	-	-
1 & 2	Operation Status	Normal Operation	1-OFF, 2-OFF
		2-stage MAX	1-ON, 2-OFF
		1-stage MIN	1-OFF, 2-ON
5 & 6	Model Setting	1-stage MAX	1-ON, 2-ON
		NFB-200H	5-OFF, 6-OFF
		NFB-175H	5-ON, 6-OFF

DIP Switch 2 (Set of 8 Switches)

SW	Function	Setting	Comment
1	Gas Type	Natural Gas	1-OFF
		Propane Gas	1-ON
2 & 3	High Altitude	0-1,999 ft (0-609 m)	2-OFF, 3-OFF
		2,000-5,399 ft (610-1,645 m)	2-ON, 3-OFF
		5,400-7,699 ft (1,646-2,346 m)	2-OFF, 3-ON
		7,700-10,100 ft (2,347-3,078 m)	2-ON, 3-ON

Refer to Table 1 on page 118 in the Installation & Operation Manual.

SW	Function	Setting	Comment
4	Reserved	-	-
5 & 6	Country	US/Canada	5-OFF, 6-OFF
7	Space Heating Thermostat	Used	7-OFF
		Unused	7-ON
8	Exhaust Temperature Control	Used	8-OFF
		Unused	8-ON

Note

- When PCB DIP switch 2 #8 is set to On, ensure that CPVC or polypropylene piping is used for exhaust venting.
- This unit may be installed at elevations up to 10,100 ft (3,078 m) for use with natural gas and propane. To use the unit at a specific altitude, the DIP switches should be set as described above.
- High Altitude: Above 2,000 ft (610 m), the unit will de-rate by 3% for each 1,000 ft (305 m) of altitude gain.
- For NG, if you install the unit at above 5,400 ft (1,646 m), it is required to change the Gas Orifice for high altitude. Be careful not to confuse it with the Gas Orifice for LP. For detail, refer to page 118 in the Installation & Operation Manual.
- Common vent installations for use with natural gas and propane are only approved for up to 4,500 ft.

STEP 3 After Installing

1 Opening All the Valves

Gas Valve

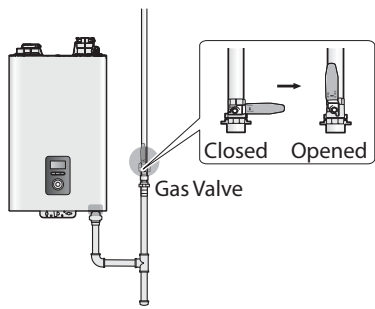

Space Heating System Valves

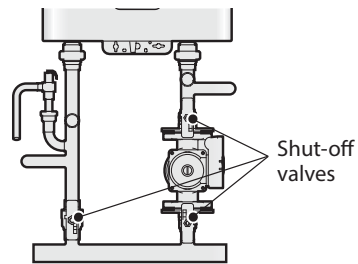

navien

Navien, Inc.
20 Goodyear, Irvine, CA 92618
Tel: 1-800-519-8794, Fax: 1-949-420-0430
www.navieninc.com

2 Operating the Boiler

Power ON

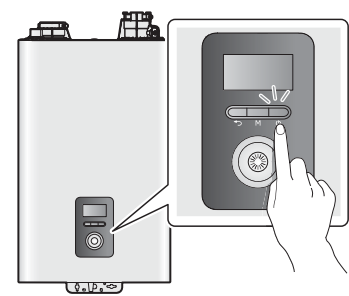

To turn the boiler on, press the Power button (⏻).

When the power is on, the boiler automatically enters normal operation mode, and the boiler's operating conditions are displayed on the screen.

Note The setup wizard should run the first time the unit is powered on. The wizard must be completed before the boiler can be used. Refer to page 96 in the Installation & Operation Manual.

Adjust Temperatures

Space Heating Temperature

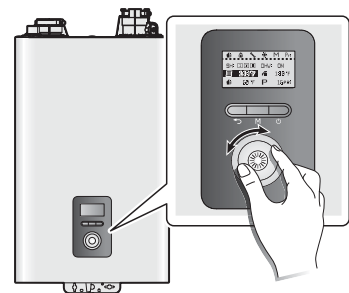

1. In normal operation mode, rotate the Command dial (⊙). The space heating temperature (III) is highlighted on the screen.
2. Press the Command dial (⊙) to select the space heating temperature. The highlighted section will flash.
3. Rotate the Command dial (⊙) to the right or left to increase or decrease the temperature.
4. Press the Command dial (⊙) to confirm the new temperature.

DHW Temperature

1. In normal operation mode, rotate the Command dial (⊙). The space heating temperature (III) is highlighted on the screen.
2. Rotate the Command dial (⊙) to the right or left to select the DHW temperature.
3. Press the Command dial (⊙) to select the indirect DHW temperature (IV). The highlighted section will flash.
4. Rotate the Command dial (⊙) to the right or left to increase or decrease the temperature.
5. Press the Command dial (⊙) to confirm the new temperature.

Note DHW temperature higher than 180 °F can cause scalding.

View Basic Information

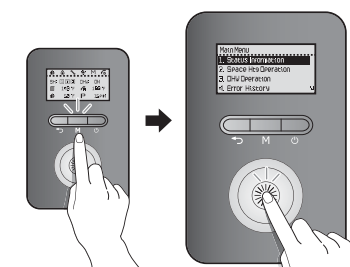

1. Press the Menu button (M), and then select "1. Status Information".
2. Rotate the Command dial (⊙) to switch between the information items.

Resetting the Boiler

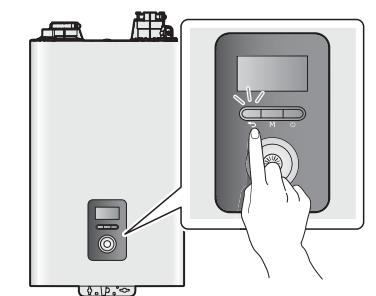

If an error message appears during boiler operation, reset the boiler to resolve the problem. Press the Back button (⏪) on the front panel to reset the boiler.

Note If resetting does not solve the problem, refer to the troubleshooting section of the User's Information Manual or contact the service center.

3 Measuring the Inlet Gas Pressure

1

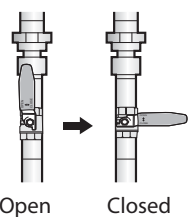

Shut off the manual gas valve.

2



Open a hot water faucet. The boiler should turn on and the gas in the gas supply line will be purged. Leave the faucet on until the boiler shuts down due to a lack of gas supply, and then turn off the hot water faucet.

3



Unfasten the 4 latches (2 at the top and 2 at the bottom) to remove the front cover and gain access to the internal components.

4

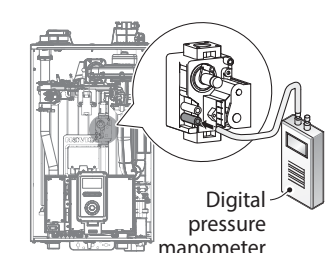

Loosen the screw indicated in the figure and connect a manometer to the pressure port. Reset the manometer to zero before use.

5

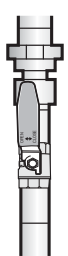

Re-open the manual gas valve and check for leaks. Activate multiple zones to ramp the boiler up to its maximum firing rate.

6



When the boiler reaches its maximum firing rate, check the inlet gas pressure reading on the manometer.

Recommended Gas Pressure Settings:
NG: 3.5"–10.5" WC
LP: 8.0"–13.0" WC

If not,



Adjust the inlet gas pressure with gas regulator.

CAUTION

The boiler cannot function properly without sufficient inlet gas pressure. **Measuring the inlet gas pressure should be performed by a licensed professional only.**

4 Installing the Front Cover

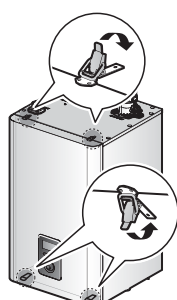

5 Ensure Maximum Water Flow

After running the boiler for the first 10 minutes, turn it off and clean the cold water filter and the space heating return strainer to remove any trapped debris.

6 Final Check

A trial run should be performed in accordance with the Installation checklist listed in the boiler's Installation & Operation Manual.