

THIS DRAWING IS INTENDED ONLY AS A GUIDE AND NOT AS A REPLACEMENT FOR PROFESSIONALLY ENGINEERED PROJECT DRAWINGS. THIS CONCEPT SYSTEM DRAWING DOES NOT IMPLY COMPLIANCE WITH LOCAL BUILDING CODES. ACTUAL INSTALLATION MAY VARY DEPENDING ON INSTALLATION LOCATION AND PARAMETERS AND IT MUST BE DONE IN ACCORDANCE TO ALL LOCAL BUILDING CODES. VERIFY WITH LOCAL BUILDINGS OFFICIALS BEFORE COMMENCEMENT OF SYSTEM INSTALLATION. CHANGES OR MODIFICATIONS TO PIPING OR DESIGN IS NOT TO BE PERFORMED WITHOUT EXPRESSED WRITTEN PERMISSION BY NAVIEN, INC.

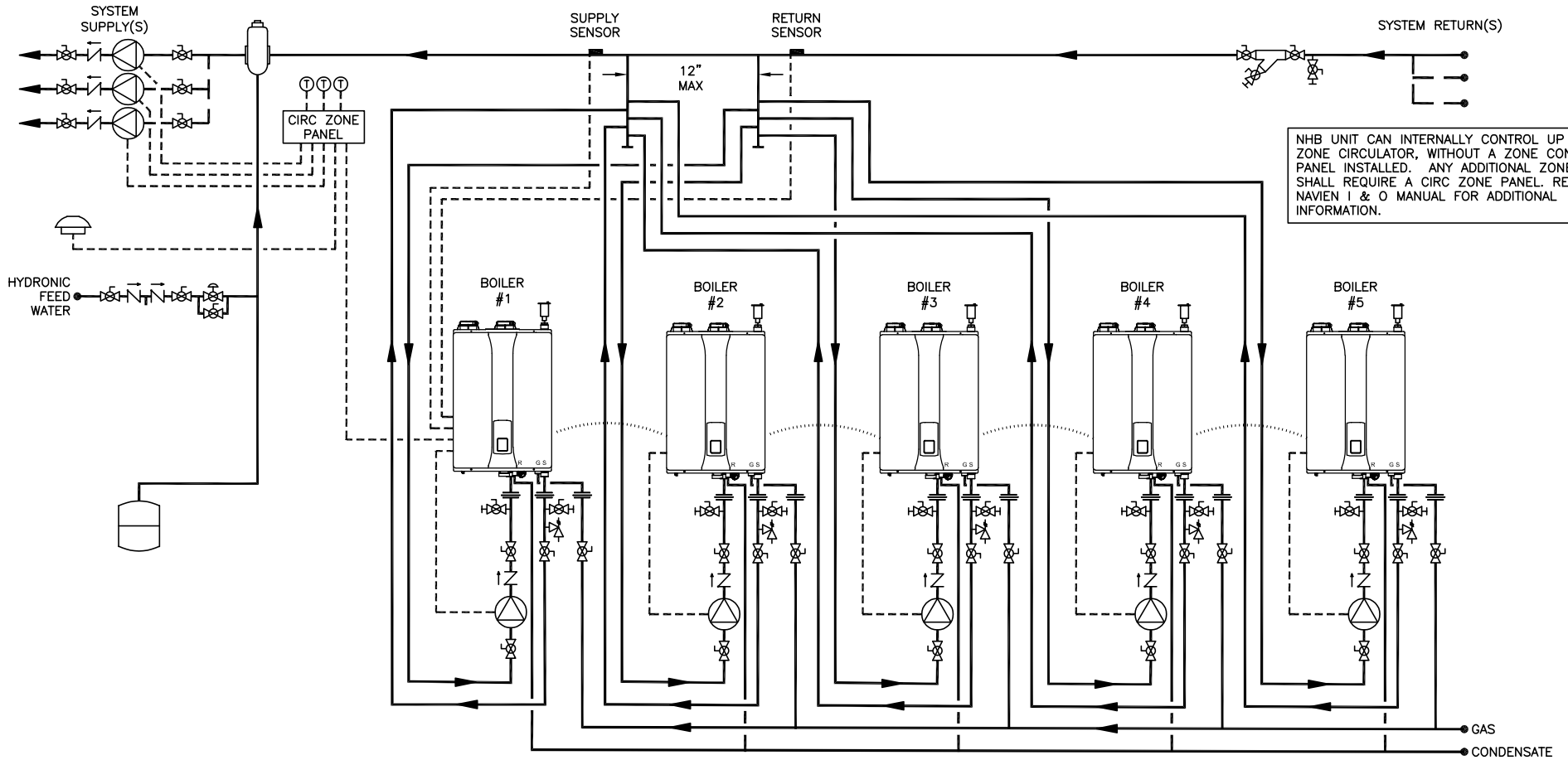

20 GOODYEAR
IRVINE, CA 92618
800-519-8794
www.navienc.com

NHB SERIES BOILER

(5) NHB BOILERS WITH
INDIVIDUAL SECONDARY INJECTION PIPING
INCLUDES MODELS NHB-55,80,110,150

DRAWN BY: S. STOEKE

NHB-5-ZP-MULT-I

AUGUST 23, 2022

SYMBOL LEGEND

	BACKFLOW PREVENTER		CHECK VALVE		FULL-PORT VALVE		EXPANSION TANK
	CONTROL WIRING		PRESSURE RELIEF VALVE		CIRCULATOR		THERMOSTAT
	OUTDOOR TEMPERATURE SENSOR		AIR ELIMINATION		UNION		BALL DRAIN VALVE
	WYE STRAINER W/ BLOWDOWN		AUTOMATIC AIR VENT		CASCADE CABLE		PRESSURE REDUCING VALVE