

# NPE-2 Series Tankless Commercial Application Guide



## NPE-Advanced 2

## NPE-Standard 2



Advanced high-efficiency tankless water heater technology for residential and commercial applications with exclusive ComfortFlow® recirculation.



Ultra condensing tankless technology for residential and commercial applications is the industry's top rated unit for energy efficiency.



# ComfortFlow<sup>®</sup>

## recirculation system

Navien ComfortFlow<sup>®</sup> is the first to incorporate a built-in insulated buffer tank and recirculation pump. The insulated buffer tank enables the NPE-A2 to operate at minimal flow rates. The built-in recirculation pump allows the NPE-A2 to recirculate water either through an external recirc line or through existing supply lines while using NaviCirc<sup>®</sup>, without the need for external pumps or controls.



# NaviLink™ & NaviLink Lite™

## NPE-A2&S2 optional Wi-Fi remote control system



Ideal for commercial or large residential use, NaviLink can support up to 24 Navien units. Units purchased before 3/23/16 may require the purchase of a new main PCB and front control panel.



NaviLink Lite is a streamlined model designed specifically for single-unit applications.



# Navien Ready-Link<sup>®</sup> manifold systems

## Now manifold mounting on a wall or rack is as simple as 1-2-3-4

**1** Pick your Navien Units, NPE-A2 or NPE-S2

**2** Pick your location, wall or rack

**3** Pick your manifold kit

**4** Pick your venting system

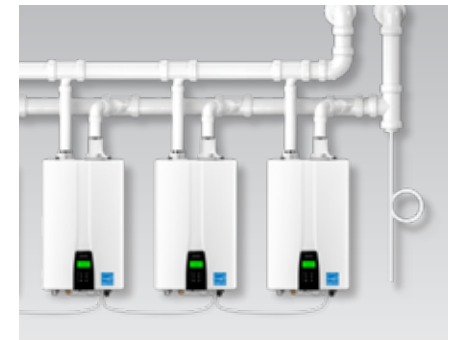
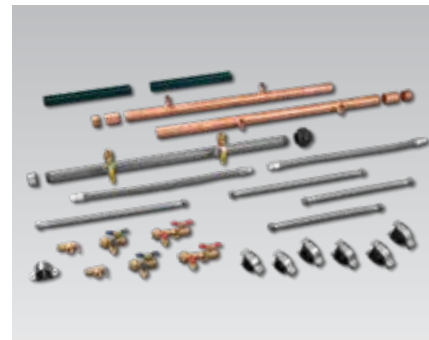
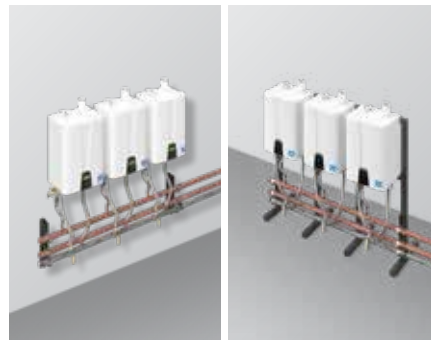

### Manifold kit components

**Each kit includes the following items in varying quantities based on the kit selected:**

- 3/4" x 3/4" Adapter
- 3/4" NPT Ball Valve
- 1-1/2" Gas Union
- 2" Copper End Cap
- 2" Copper Coupling
- 2-1/8" Strut Clamp
- Hardware Kit
- 3/4" Service Valves with PRV
- 1-5/8" x 18" Strut Channel (14ga)
- 3/4" x 24" SS Corrugated Flex Connector
- 3/4" x 30" Gas Flex Connector
- 3/4" x 18" SS Corrugated Flex Connector
- 1-1/2" FPT Galvanized Iron End Cap
- 1-7/8" OD Strut Clamp

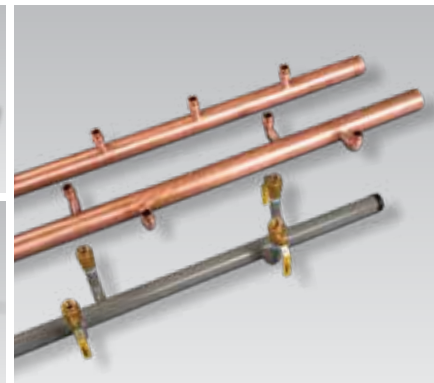
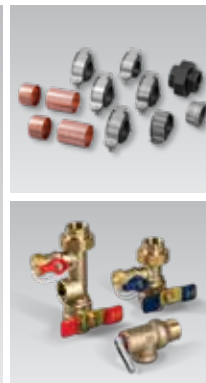
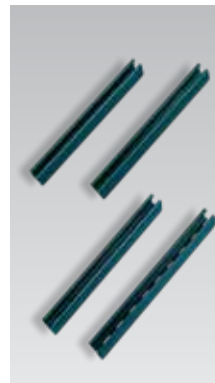

## Simple same day assembly

No waiting for expensive bulky factory assembled racks. Everything is available at your local Navien wholesaler with an easy to follow installation manual.

## Simple to transport

Every component of the system is portable for easy pickup and setup. All parts of the kit fit through a standard door opening.

## Simple to expand

Ready-Link® wall or rack manifold kits can be built in 30 configurations from 2–16 units. NPE-2 series can common venting up to 12 units and cascade up to 32 units.

## Simple way to make more money

You handle the installation yourself, on your terms and time frame.

### Back-to-back kits

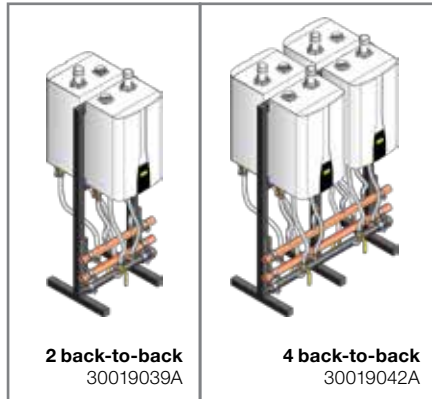

### Side-by-side kits

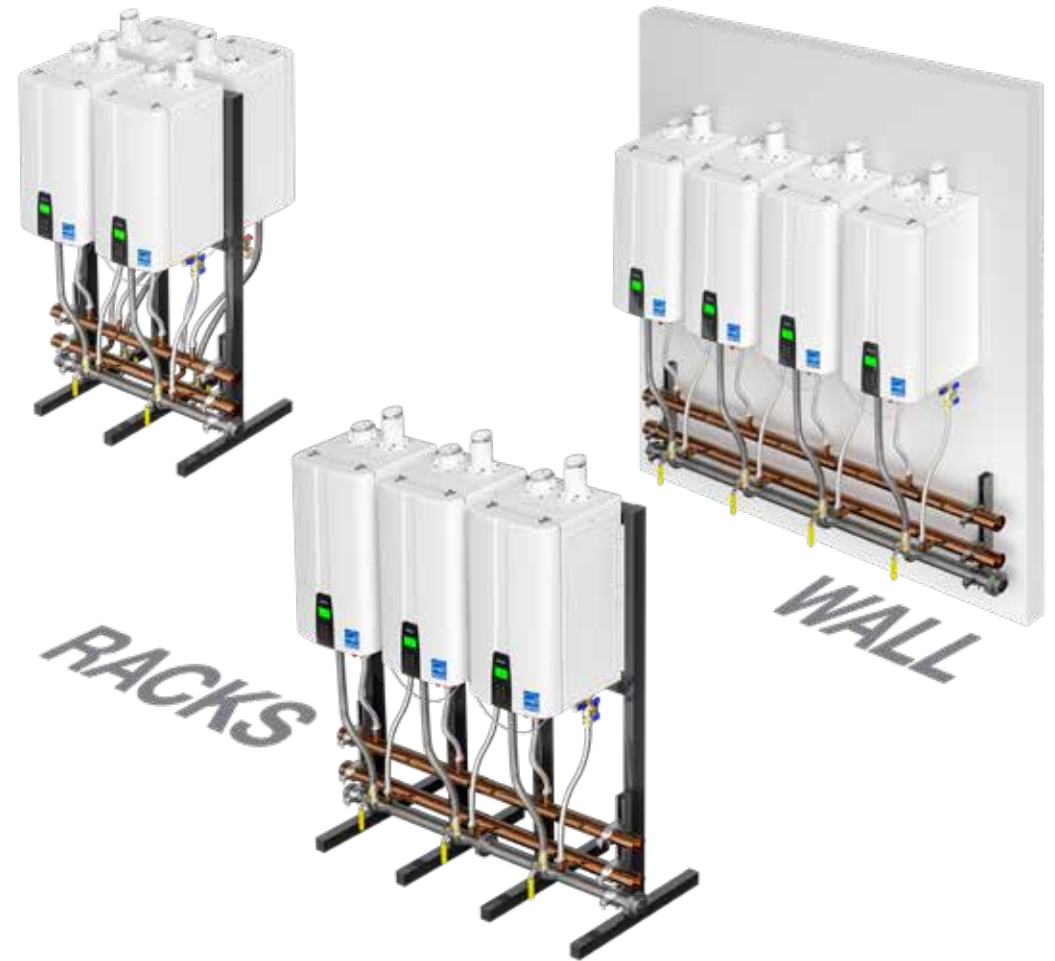
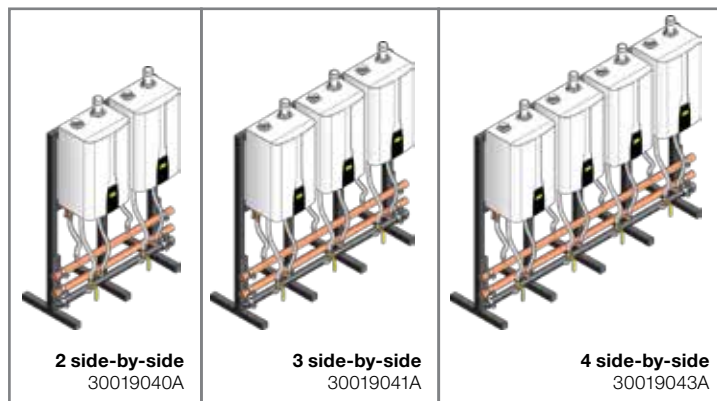

Ready-Link® rack base and add-on components sold separately.

## Determine GPM/GPH flow rate requirement and reference tankless count or tankless count and storage tank requirements in chart

NPE-240A2 or NPE-240S2 199,900 BTU/H Tankless Water Heater Application Guide All Calculations are Based on a 100 Degree Fahrenheit Temperature Rise														
Tankless Count	Tankless Only Application Flow Rates		Tankless with Storage Gallons per Hour (GPH)/1st Hour (2) All Calculations are Based on a 100 Degree Fahrenheit Temperature Rise											
	GPM Flow @ 100°F Rise	GPH Flow @ 100°F Rise (1)	20 Gallons	30 Gallons	40 Gallons	50 Gallons	80 Gallons	120 Gallons	160 Gallons	200 Gallons	240 Gallons	320 Gallons	360 Gallons	480 Gallons
1	3.9	234	249	257	264	272	294	324	354	384	414	474	504	594
2	7.8	468	483	491	498	506	528	558	588	618	648	708	738	828
3	11.7	702	717	725	732	740	762	792	822	852	882	942	972	1,062
4	15.6	936	951	959	966	974	996	1,026	1,056	1,086	1,116	1,176	1,206	1,296
5	19.5	1,170	1,185	1,193	1,200	1,208	1,230	1,260	1,290	1,320	1,350	1,410	1,440	1,530
6	23.4	1,404	1,419	1,427	1,434	1,442	1,464	1,494	1,524	1,554	1,584	1,644	1,674	1,764
7	27.3	1,638	1,653	1,661	1,668	1,676	1,698	1,728	1,758	1,788	1,818	1,878	1,908	1,998
8	31.2	1,872	1,887	1,895	1,902	1,910	1,932	1,962	1,992	2,022	2,052	2,112	2,142	2,232
9	35.1	2,106	2,121	2,129	2,136	2,144	2,166	2,196	2,226	2,256	2,286	2,346	2,376	2,466
10	39.0	2,340	2,355	2,363	2,370	2,378	2,400	2,430	2,460	2,490	2,520	2,580	2,610	2,700
11	42.9	2,574	2,589	2,597	2,604	2,612	2,634	2,664	2,694	2,724	2,754	2,814	2,844	2,934
12	46.8	2,808	2,823	2,831	2,838	2,846	2,868	2,898	2,928	2,958	2,988	3,048	3,078	3,168
13	50.7	3,042	3,057	3,065	3,072	3,080	3,102	3,132	3,162	3,192	3,222	3,282	3,312	3,402
14	54.6	3,276	3,291	3,299	3,306	3,314	3,336	3,366	3,396	3,426	3,456	3,516	3,546	3,636
15	58.5	3,510	3,525	3,533	3,540	3,548	3,570	3,600	3,630	3,660	3,690	3,750	3,780	3,870
16	62.4	3,744	3,759	3,767	3,774	3,782	3,804	3,834	3,864	3,894	3,924	3,984	4,014	4,104

(1) Tankless unit only system has controlled outlet temperature/flow. GPH requirement should be considered to be the peak maximum GPM flow rate x 60 min.  
Ex: One NPE-240A2/NPE-240S2 is 3.9 GPM @ 100°F Rise x 60 min = 234 GPH.

(2) Tankless with Storage GPH 1st hour output is calculated by tankless recovery rate and 75% of available storage capacity.

NPE-A2 Advanced Tankless includes Internal Circulator & Buffer Tank commonly used for recirculation systems and quicker hot water response and no minimal flow rate requirements.

NPE-S2 Standard Tankless commonly used when Storage is applied with required external circulator(s) and situations that have high volumes of domestic hot water draws.

A minimum of two tankless units is recommended in all commercial applications.

## NPE-A2 or NPE-S2 commercial applications existing replacement guide

NPE-A2 Advanced Tankless Includes Internal Circulator & Buffer Tank – NPE-S2 Standard Tankless		
Existing or Specified Tank Water Heater / Equipment	Navien Equipment Required	
	Tankless Only	Tankless w/Storage (a)
(1) 65-80 MBTU/H/65–100 Gallon Tank	2 – NPE-240 (A2 or S2)	1 – NPE-240S2 and 1 – 80/120 Gal Tank
(1) 180–199 MBTU/H/100 Gallon Tank	3 – NPE-240 (A2 or S2)	2 – NPE-240S2 and 1 – 120 Gal Tank
(1) 250 MBTU/H/100 Gallon Tank	4 – NPE-240 (A2 or S2)	2 – NPE-240S2 and 1 – 80/120 Gal Tank
(1) 275 MBTU/H/100 Gallon Tank	4 – NPE-240 (A2 or S2)	2 – NPE-240S2 and 1 – 120 Gal Tank
(1) 310–399 MBTU/H/100 Gallon Tank	5 – NPE-240 (A2 or S2)	3 – NPE-240S2 and 1 – 120 Gal Tank
(1) 400 MBTU/H/80–100 Gallon Tank	5 – NPE-240 (A2 or S2)	3 – NPE-240S2 and 1 – 120 Gal Tank

(a) Tankless with storage tank does not reach Navien Energy Efficiency ratings published due to standby and piping losses, lower unit flow rates and temperature rise operation.

1. Always use Bronze or Stainless Steel trimmed domestic water circulators for both tankless to tank operations as well as domestic recirculation function.

2. Above reference guide provided should be verified with actual application and domestic hot water requirements.

## NPE-2 temperature rise performance/NPE-240A2 circulator & flow rate

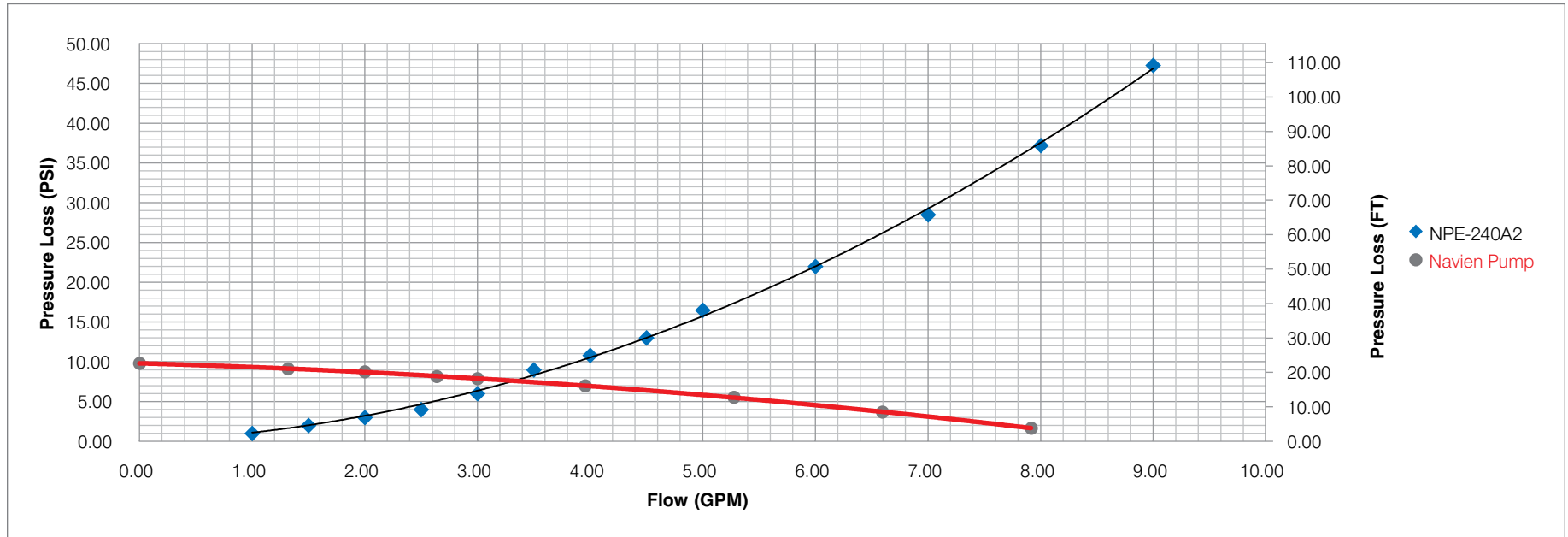

NPE-240A2/S2 (199,900 BTU/H)													
Flow (GPM)	1.00	1.50	2.00	2.50	3.00	3.50	4.00	4.50	5.00	6.00	7.00	8.00	9.00
Loss (PSI)	1.00	2.00	3.00	4.00	6.00	9.00	10.80	13.00	16.50	22.00	28.50	37.20	47.30
Loss (FT)	2.31	4.62	6.93	9.24	13.86	20.79	24.95	30.03	38.12	50.82	65.84	85.93	109.26
°F Temperature Rise	≥150	≥150	≥150	≥150	129.27	110.81	96.96	86.18	77.57	64.64	55.40	48.48	43.09

NPE-A2 Series Navien Circulation Pump										
Flow (LPM)	0.00	5.00	7.58	10.00	11.37	15.00	20.00	25.00	30.00	Selection Criteria
Flow (GPM)	0.00	1.32	2.00	2.64	3.00	3.96	5.28	6.60	7.92	Recommended Heat Exchanger Flow Rates
Head (PSI)	9.82	9.11	8.76	8.16	7.87	6.98	5.56	3.67	1.66	Not Recommended
Head (FT)	22.68	21.04	20.24	18.85	18.18	16.12	12.84	8.48	3.83	Exceeds Heat Exchanger Pressure Drop



## Multiple NPE-A2 with external recirculation example using tankless internal circulator(s)

Total external piping distance (distribution and return line) should be limited to 300 ft.

THIS DRAWING IS INTENDED ONLY AS A GUIDE AND NOT AS A REPLACEMENT FOR PROFESSIONALLY ENGINEERED PROJECT DRAWINGS. THIS CONCEPT SYSTEM DRAWING DOES NOT IMPLY COMPLIANCE WITH LOCAL BUILDING CODES. ACTUAL INSTALLATION MAY VARY DEPENDING ON INSTALLATION LOCATION AND PARAMETERS AND IT MUST BE DONE IN ACCORDANCE TO ALL LOCAL BUILDING CODES. VERIFY WITH LOCAL BUILDINGS OFFICIALS BEFORE COMMENCEMENT OF SYSTEM INSTALLATION. CHANGES OR MODIFICATIONS TO PIPING OR DESIGN IS NOT TO BE PERFORMED WITHOUT EXPRESSED WRITTEN PERMISSION BY NAVIEN, INC.

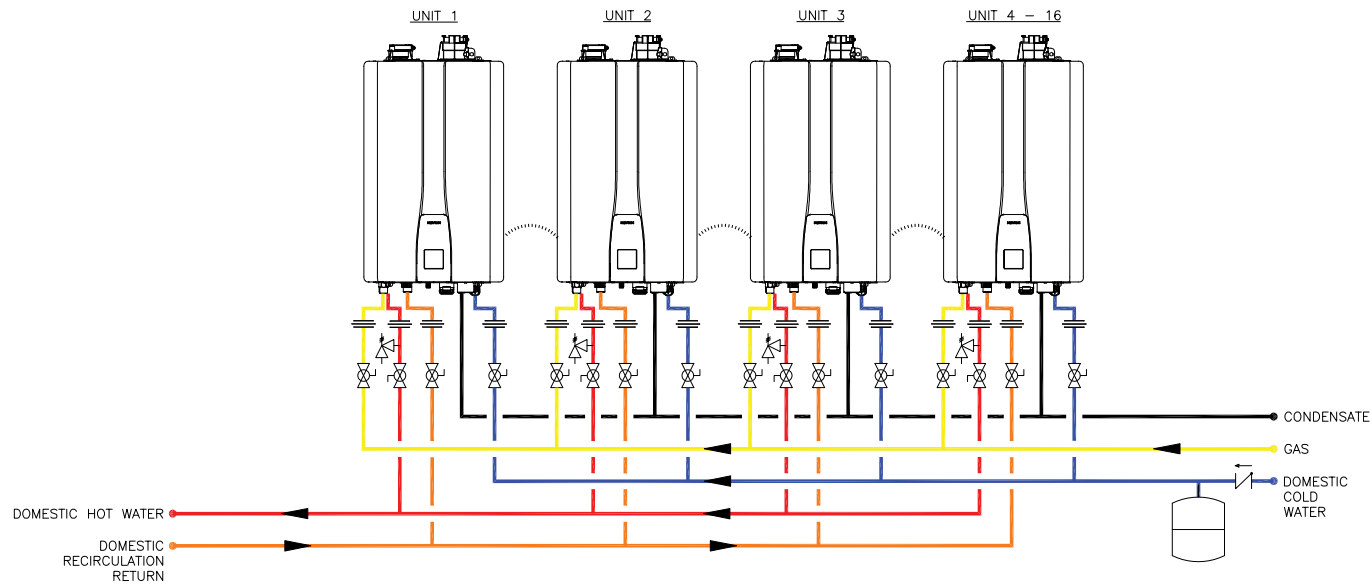

TANKLESS QUANTITY: RECOMMENDED PIPE SIZE	1 UNIT: 3/4"	2 UNITS: 1"	3 UNITS: 1-1/4"	4-5 UNITS: 1-1/2"	6-8 UNITS: 2"	9-14 UNITS: 2-1/2"	15-16 UNITS: 3"	SYMBOL LEGEND			
 20 GOODYEAR IRVINE, CA 92618 800-519-8794 www.navienc.com	NPE-A2 SERIES TANKLESS WATER HEATER							UNION	CHECK VALVE	FULL-PORT VALVE	EXPANSION TANK
	(4 PLUS) NPE-A2 TANKLESS WATER HEATERS WITH EXTERNAL RECIRCULATION MODE INCLUDES MODELS 180, 210 AND 240							CASCADE CABLE	PRESSURE RELIEF VALVE		
DRAWN BY:	S. STOEKE	NPE-A2-4PLUS-E				APRIL 20, 2021					

For Application Drawings, Specifications, CAD and Revit files, visit:  
[Navieninc.com/specs](http://Navieninc.com/specs)

## Multiple NPE-A2 with external recirculation example using internal circulators with external building recirculation pump

Internal NPE-A2 circulators maintain tankless flow requirements, select external pump(s) to meet external piping requirements (head & flow).

THIS DRAWING IS INTENDED ONLY AS A GUIDE AND NOT AS A REPLACEMENT FOR PROFESSIONALLY ENGINEERED PROJECT DRAWINGS. THIS CONCEPT SYSTEM DRAWING DOES NOT IMPLY COMPLIANCE WITH LOCAL BUILDING CODES. ACTUAL INSTALLATION MAY VARY DEPENDING ON INSTALLATION LOCATION AND PARAMETERS AND IT MUST BE DONE IN ACCORDANCE TO ALL LOCAL BUILDING CODES. VERIFY WITH LOCAL BUILDINGS OFFICIALS BEFORE COMMENCEMENT OF SYSTEM INSTALLATION. CHANGES OR MODIFICATIONS TO PIPING OR DESIGN IS NOT TO BE PERFORMED WITHOUT EXPRESSED WRITTEN PERMISSION BY NAVIEN INC.

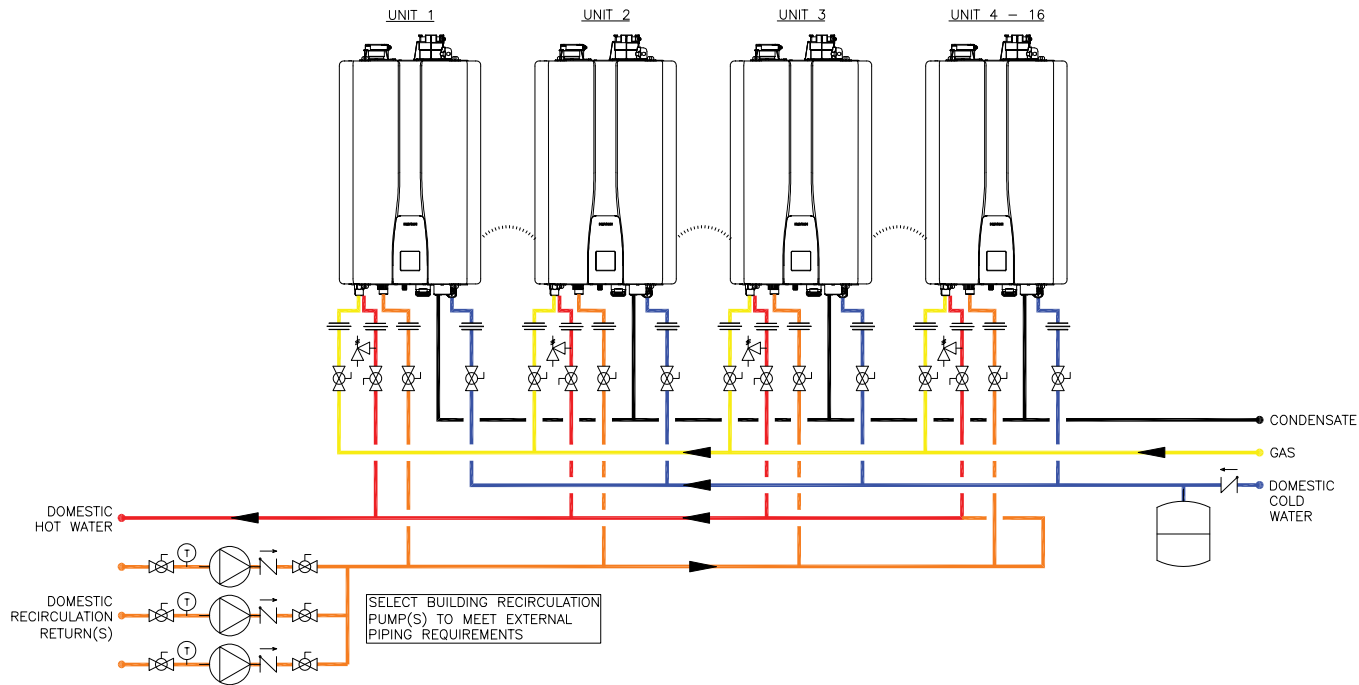

TANKLESS QUANTITY: RECOMMENDED PIPE SIZE	1 UNIT: 3/4"	2 UNITS: 1"	3 UNITS: 1-1/4"	4-5 UNITS: 1-1/2"	6-8 UNITS: 2"	9-14 UNITS: 2-1/2"	15-16 UNITS: 3"	SYMBOL LEGEND	
 20 GOODYEAR IRVINE, CA 92618 800-519-8794 www.navieninc.com								UNION CHECK VALVE FULL-PORT VALVE EXPANSION TANK CASCADE CABLE PRESSURE RELIEF VALVE CIRCULATOR AQUASTAT	
NPE-A2 SERIES TANKLESS WATER HEATER (4 PLUS) NPE-A2 TANKLESS WATER HEATERS EXTERNAL RECIRCULATION MODE WITH EXTERNAL CIRCULATOR(S) INCLUDES MODELS 180, 210 AND 240									
DRAWN BY:	S. STOEKE	NPE-A2-4PLUS-ECS			APRIL 20, 2021				

For Application Drawings, Specifications, CAD and Revit files, visit:  
[Navieninc.com/specs](http://Navieninc.com/specs)

## Multiple NPE-S2 with external recirculation example using an external circulator

Suggested maximum flow is 3 GPM through tankless with a minimum flow of 2 GPM. Proper selection of external circulator requires meeting the external piping requirements (head & flow) pressure drops of NPE-S2 tankless water heaters. Select external circulator to pump 50% of total heater count @ 5 PSI pressure drop/12 ft. head.

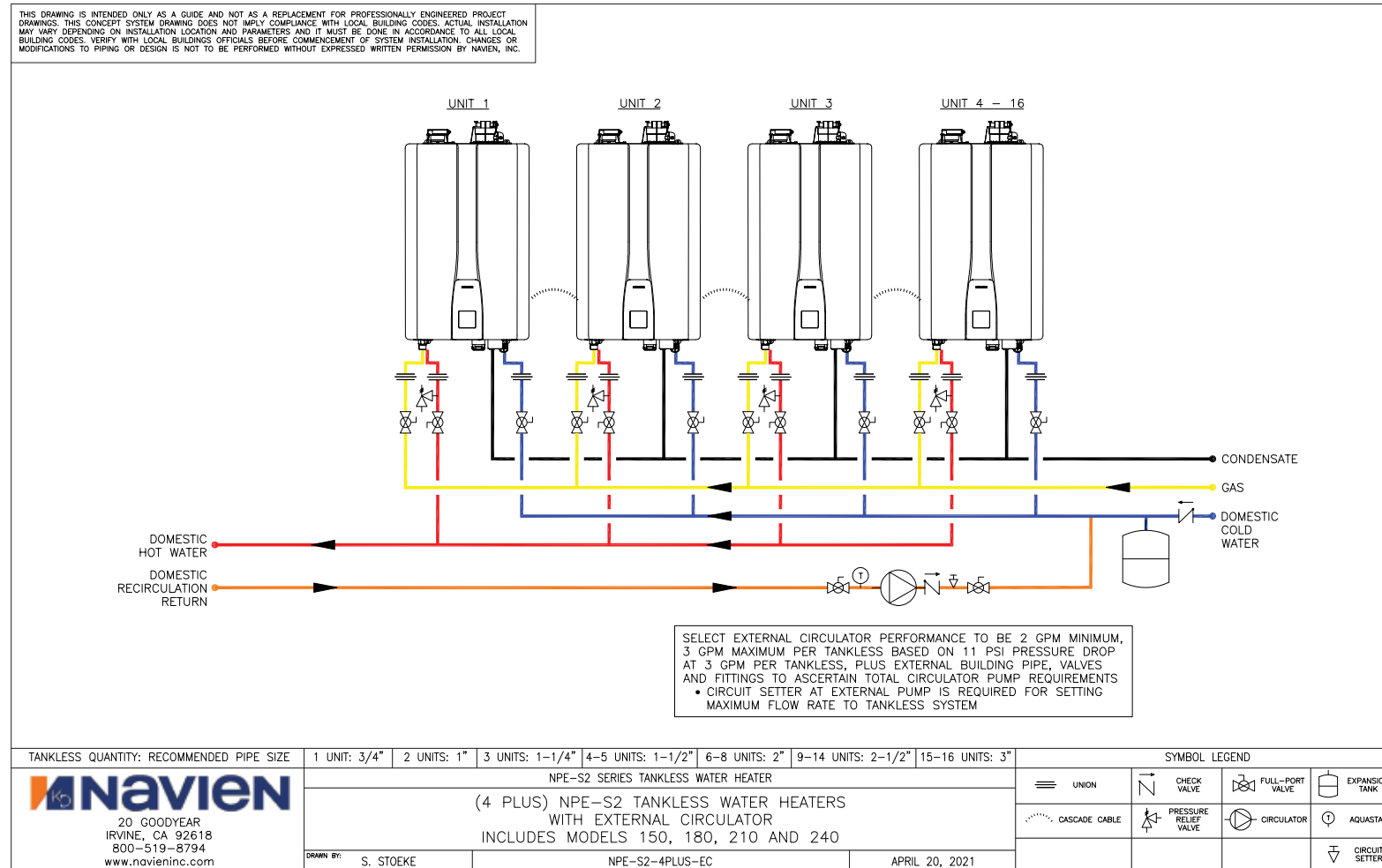

For Application Drawings, Specifications, CAD and Revit files, visit:

[Navieninc.com/specs](http://Navieninc.com/specs)

T H E L E A D E R I N C O N D E N S I N G T E C H N O L O G Y

## Multiple NPE-S2 with storage tank example

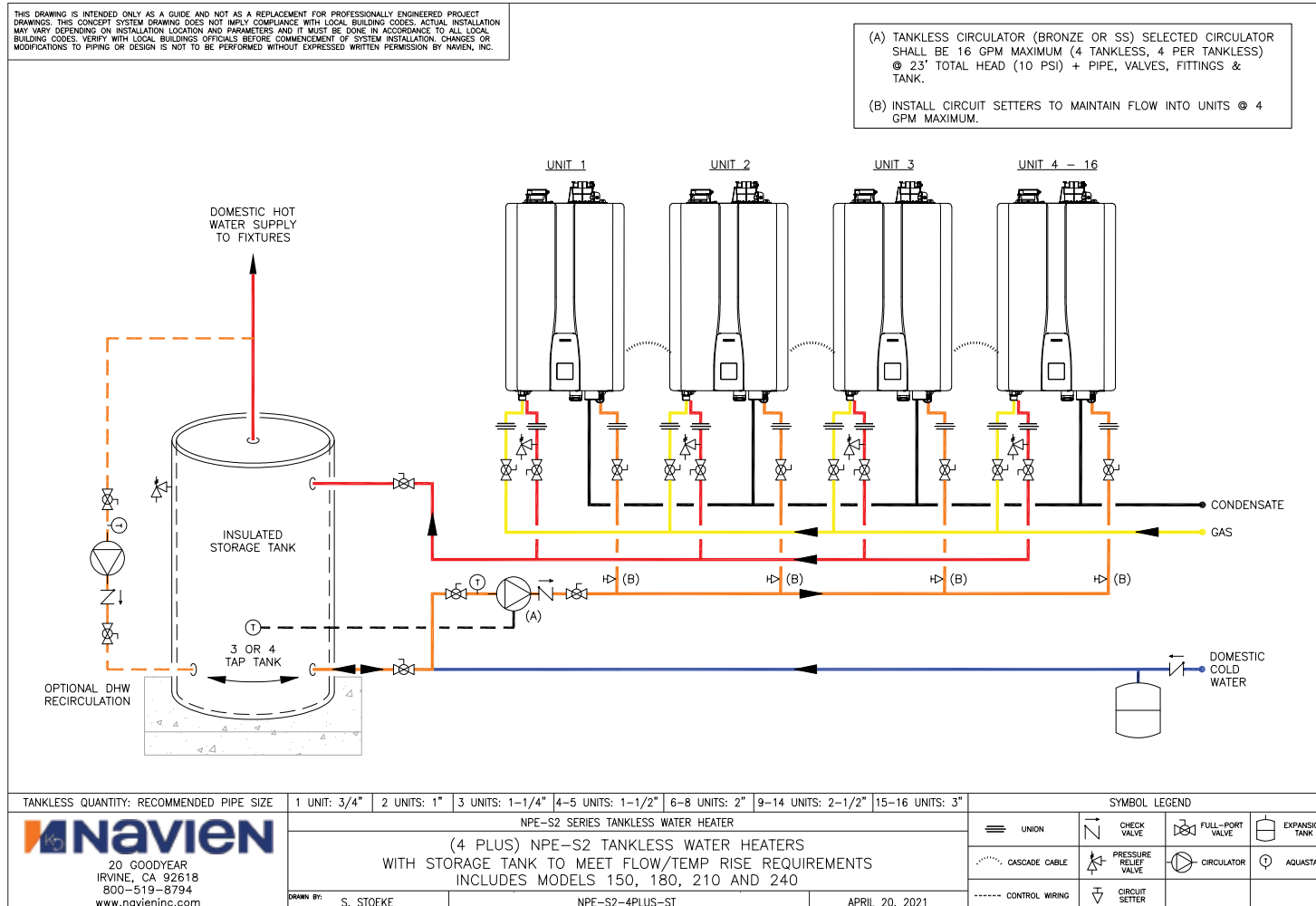

For Application Drawings, Specifications, CAD and Revit files, visit:  
[Navieninc.com/specs](http://Navieninc.com/specs)

## Multiple NPE-S2 with storage tank circulator pump sizing

NPE-240S2 Series Tankless		Manifold/Pipe Size Minimum
Number of Navien NPE-240S2 Heaters	Pump Flow Requirements (b)	
1	4 GPM @ 26' head (11 PSI)	3/4"
2	8 GPM @ 26' head (11 PSI)	1"
3	12 GPM @ 26' head (11 PSI)	1-1/4"
4	16 GPM @ 26' head (11 PSI)	1-1/2"
5	20 GPM @ 26' head (11 PSI)	1-1/2"
6	24 GPM @ 26' head (11 PSI)	2"
7	28 GPM @ 26' head (11 PSI)	2"
8	32 GPM @ 26' head (11 PSI)	2"
9	36 GPM @ 26' head (11 PSI)	2-1/2"
10	40 GPM @ 26' head (11 PSI)	2-1/2"
11	44 GPM @ 26' head (11 PSI)	2-1/2"
12	48 GPM @ 26' head (11 PSI)	2-1/2"

(b) Additional pressure losses in plumbing between the Navien(s) and the storage tank or total piping of recirculation loop must also be taken into consideration and added. Flow rates and pressure drop requirements shown are calculated with all Flow Adjustment Valves programmed open.

## Navien NPE-S2 Series tankless water heater with storage tank circulator selection guide

Navien NPE-2 Unit Count	Unit Flow Rate	Total System GPM	Recommended Pipe Manifold Size	Grundfos	Taco	Bell & Gossett	Armstrong	Wilo
1	Maximum Acceptable Pump Flow Rate per Unit 4 GPM	4	3/4"	UP26-96BF, UP26-99BF	0011-SF4, 0013-SF3	NBF-36, PL-36B & 45B	E8.2B, E9.2B	STAR Z S21
2		8	1"	UP26-99BF, UPS26-150SF	0013-SF3	PL-36B	E9.2B, E23.2B	STAR Z S21
3		12	1-1/4"	UPS26-150SF	2400-20S	PL-55B	E9.2B, E23.2B	STAR Z S33
4		16	1-1/2"	UPS26-150SF	2400-45S, 133B	PL-55B	E9.2B, E23.2B	STAR Z S33
5		20	1-1/2"	UPS26-150SF, UPS32-160B	2400-45S, 133B	PL-55B	E9.2B, E23.2B	STAR Z S33
6		24	2"	UPS32-160B	2400-50S, 133B	PDB-40S	E22.2B	STAR Z S33
7		28	2"	UPS32-160B	2400-50S, 133B	PDB-40S	E22.2B	STRATOS-Z 1.25x3-35
8		32	2"	UPS32-160B	1612B, 133B	PDB-40S	H64B	
9		36	2-1/2"	UPS32-160B	1614B, 133B	PDB-40S	H64B	
10		40	2-1/2"	UPS40-160B	1614B, 133B	PDB-40S	H64B	
11		44	2-1/2"	UPS40-160B	1614B, 133B	PDB-40S	H64B, H67B	
12		48	2-1/2"	UPS40-160B	1614B, 133B	PDB-40S	H67B	

Suggested 115V/1 Ph. circulator models and sizes are for reference only.

Proper verification of required sizes must be confirmed with specific installation and application.

Note; tankless units may be able to be split up into banks of heaters to allow smaller pump selections.

Contact Navien for technical assistance with applications requiring more than 12 NPE-2 Series Heaters in Pump/Tank Applications.

## Commercial and general tankless application sizing using ASHRAE modified Hunter Curve

Determine the total fixture unit load for all the fixtures serviced by your water heater application using the ASHRAE modified Hunter Curve hot fixture units table.

Using the total fixture units for your application, enter the Hunter Curves using ASHRAE modified Hunter Curve – flow chart (0-100 or 0-500) from the bottom on the total fixture units line for your application. Read up to the curve that best fits the application. Then read to the left for the corresponding GPM requirement.

Example: Apartment building (50 units, 25 1-bath, 25 2-bath)

No. Fixtures	Type of Fixture	Fix. Unit	Demand Fix. Unit
75	Private Lavatory	.75	56.25
75	Tub & Shower	1.5	112.5
50	Sink-Kitchen	.75	37.5
50	Domestic Dishwasher	1.5	75
50	Domestic Clothes Washer	1.2	60
<b>Total Fixture Units</b>			<b>342</b>

Refer to the modified Hunter Curves in chart(s) included on the next pages. Curve C represents apartments. Enter the graph from the bottom at 342 fixture units and go up to curve C. Then move to the left horizontally to read approximately 45 gallons per minute of hot water capacity required.

Determine temperature rise required based on coldest inlet water temperature (winter).

Example: 40°F inlet cold water heated to 140°F = 100°F rise

°F Rise	GPM	°F Rise	GPM	°F Rise	GPM	°F Rise	GPM
30	13.0	50	7.8	70	5.6	90	4.3
35	11.1	55	7.1	75	5.2	95	4.1
40	9.7	60	6.5	80	4.9	100	3.9
45	8.7	65	6.0	85	4.6	105	3.7

Calculation:  $199,900 \text{ BTU/H input (NPE-240A2/NPE-240S2)} / 8.34 \text{ (gal of water)} / 60 \text{ (minutes)} / 100 \text{ (temp rise)} \times .97 \text{ (efficiency)} = 3.875 \text{ GPM}$

Using a temperature rise of 100°F, 45 GPM apartment hot water requirement / 3.9 GPM per tankless = 12 NPE-240A2/NPE-240S2 tankless required

## Commercial and general tankless application sizing with storage using ASHRAE modified Hunter Curve

### BTU/H input requirement (tankless count required with storage tank)

1. Apply the modified Hunter Curve to fixture count
2. Use chart to convert to GPM
3. Determine coldest incoming water temperature
4. Select desired storage tank outlet temperature
5. Calculate the temperature rise
6. Multiply the GPM x (Temperature Rise) x 500 = BTU/H required
7. Apply a diversity factor of .60
8. Divide BTU/H by 199,900 to determine the number of Navien NPE-240A2/NPE-240S2 tankless units required

### Sizing the minimum storage tank size

1. Total number of tankless units required calculated above multiplied by 40 = minimal size of storage required in gallons

Example: Apartment building (50 units, 25 1-bath, 25 2-bath)

No. Fixtures	Type of Fixture	Fix. Unit	Demand Fix. Unit
75	Private Lavatory	.75	56.25
75	Tub & Shower	1.5	112.5
50	Sink-Kitchen	.75	37.5
50	Domestic Dishwasher	1.5	75
50	Domestic Clothes Washer	1.2	60
<b>Total Fixture Units</b>			<b>342</b>

Equipment required: 7 NPE-240S2 & 280 gallons of storage



# ASHRAE modified Hunter Curve — hot water fixture units (140°F)

Hospital	
Type of Fixture	No. Units
Private Lavatory	0.75
Public Lavatory	1.00
Semi-Private Lavatory	1.20
†Private Shower	1.50
†Ward Shower	2.50
†Semi-Private Shower	1.50
Private Bath	1.50
Ward Bath	2.00
Sink — Flushing Rim	2.00
Sink — Scrub-Up	1.50
Sink — Laboratory	1.50
Sink — General Purpose	1.00
Bath — Leg	6.00
Bath — Arm	4.00
Bath — Sitz	3.00
Bath — Foot	3.00
Bath — Emergency	2.00
Hydrotherapeutic Showers	
#1 Shower Head	8.00
#2 Spray	12.00
Continuous Flow Bath	
Continuous Flow Fill	2.00
Continuous Flow Operate	1.50
Hubbard	4.00
Autopsy Table	2.00
Autopsy Sink and Table	2.50

Club	
Type of Fixture	No. Units
Private Lavatory	0.75
Public Lavatory	1.00
†Private Shower	1.50
†Public Shower	1.70
†Tub and Shower	1.50
Sink — Slop	2.50
36" Half Bradley	1.00
36" Full Bradley	1.50
54" Half Bradley	1.50
50" Full Bradley	2.00

Gymnasium	
Type of Fixture	No. Units
Private Lavatory	0.75
Public Lavatory	1.00
Private Shower	1.50
Public Shower	3.00
Sink — Slop	1.50
Basin — Foot	1.20
36" Half Bradley	1.00
36" Full Bradley	1.50
54" Half Bradley	1.50
54" Full Bradley	2.00

Associate Building, YMCA	
Type of Fixture	No. Units
Private Lavatory	0.75
Public Lavatory	1.00
Private Shower	1.50
Public Shower	3.00
Sink — Slop	1.50
Basin — Foot	1.20

Restaurant**	
Type of Fixture	No. Units
Private Lavatory	0.70
Public Lavatory	2.00
†Private Shower	1.50
†Public Shower	1.70
Sink — Kitchen	3.00
Sink — Pantry	2.50
Sink — Slop	2.00
Sink — Pot (Single)	2.50
Sink — Pot (Double)	3.50
Sink — Pot (Triple)	5.50
Sink — Vegetable	2.00
Sink — Bar	2.50
Washer — Silver *	2.00
Washer — Glass *	2.00
Washer — Can	3.00
Coffee Urn	1.20
Bain Marie	1.00
Pot and Pan Washer *	2.00

Restaurant**	
Type of Fixture	No. Units
Dish Pre-Rinse	2.50
Pre-Scraper	2.00
Pre-Scraper Conveyor	2.50
36" Half Bradley	1.00
36" Full Bradley	1.50

Dishwashers* (140°F)	
Type of Fixture	No. Units
Stationary Rack	
16" x 16" Rack	2.50
18" x 18" Rack	3.90
20" x 20" Rack	4.20
Multiple Tank Conveyor Type	
Dishes — Inclined	2.00
Dishes — Flat	2.50
Single Tank Conveyor Type	2.30

Hotel/Motel	
Type of Fixture	No. Units
Private Lavatory	0.75
Public Lavatory	1.00
†Private Shower	1.50
†Tub and Shower	1.50
Basin — Barber	2.00
Sink — Slop	2.50
Basin — Beauty Parlor	2.50

Office Building	
Type of Fixture	No. Units
Private Lavatory	0.75
Public Lavatory	1.00
Private Shower	1.50
Sink — Slop	2.50
Janitor Drop	2.50
36" Half Bradley	1.00
36" Full Bradley	1.50

Factory	
Type of Fixture	No. Units
Private Lavatory	0.75
Public Lavatory	1.00
†Private Shower	1.50
†Public Shower	3.00
Sink — Slop	2.50
36" Half Bradley	1.00
36" Full Bradley	1.50
54" Half Bradley	1.50
54" Full Bradley	2.00

Correctional or Mental Institutions	
Type of Fixture	No. Units
Private Lavatory	0.70
Public Lavatory	1.00
†Private Shower	1.50
†Public Shower	3.00
†Tub and Shower	1.50
Sink — Slop	2.00
Janitor Drop	2.00
36" Half Bradley	1.00
36" Full Bradley	1.50
54" Half Bradley	1.50
54" Full Bradley	2.00

Apartment	
Type of Fixture	No. Units
Private Lavatory	0.75
Public Lavatory	1.00
†Private Shower	1.50
†Public Shower	1.50
†Tub and Shower	1.50
Sink — Kitchen	0.75
Sink — Slop	1.50
Sink — Pantry	1.50
Domestic Clothes Washer	1.20
Domestic Dishwasher	1.50
Laundry Tray	1.50

Private/Public School	
Type of Fixture	No. Units
Private Lavatory	0.75
Public Lavatory	1.00
†Private Shower	1.50
†Tub and Shower	1.70
Sink — Slop	2.50
Janitor Drop	1.50
Domestic Clothes Washer	2.00
Domestic Dishwasher	2.00

Institution/Home	
Type of Fixture	No. Units
Private Lavatory	0.70
Public Lavatory	1.00
†Private Shower	1.50
†Tub and Shower	1.50
Sink — Slop	2.00
Janitor Drop	2.00

Commercial Laundry	
Type of Fixture	No. Units
4 GPM x Total Machine Capacity in Pounds	
60 Minutes	
Example: 4 GPM x 60#s / 60 min = 4 Fixture Units (One 60# commercial washer)	

\* These items may require 180°F hot water. The consumption figures are based on supplying 140°F water with a booster heater used to obtain 180°F water.

\*\* Add 20% to all figures when not used in combination with other building services from same heater.

† The fixture units listed for shower heads are based on a flow rate of 3 GPM. These units should be corrected for other flow rates. Multiply the fixture units by Correction Factor "C" from the formula: C = G x .33, where C = Correction Factor and G = GPM of shower head being used.

Example: Shower head 4 GPM = C = 4 x .33 or 1.32. From Fixture Units Table, Hotel-Motel (shower) which shows 1.5 fixture units, multiply 1.5 x 1.32 = 2.10 fixture units per shower head using 4 GPM.

### ASHRAE modified Hunter Curve — flow chart (0-100)

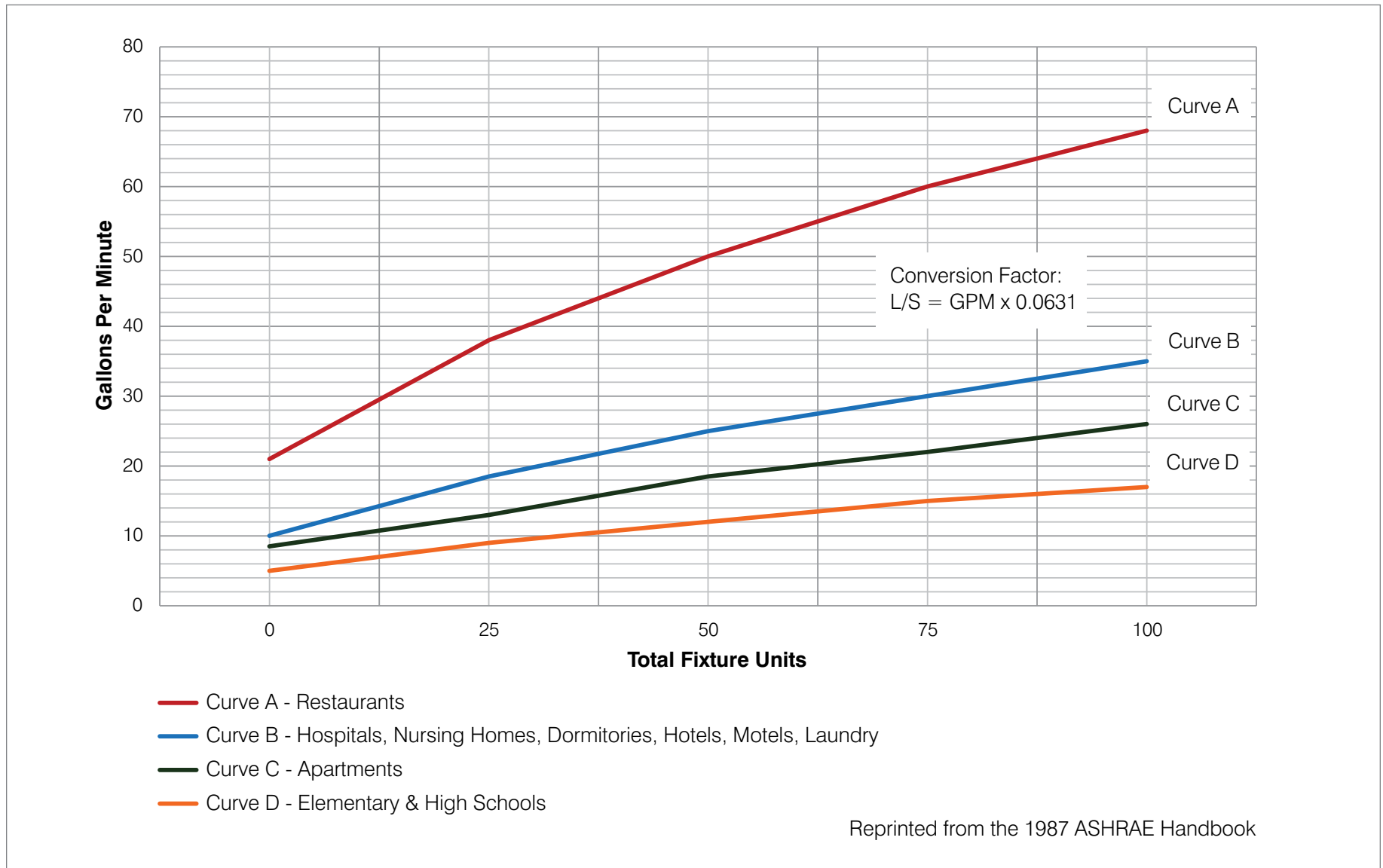

## ASHRAE modified Hunter Curve — flow chart (0-500)

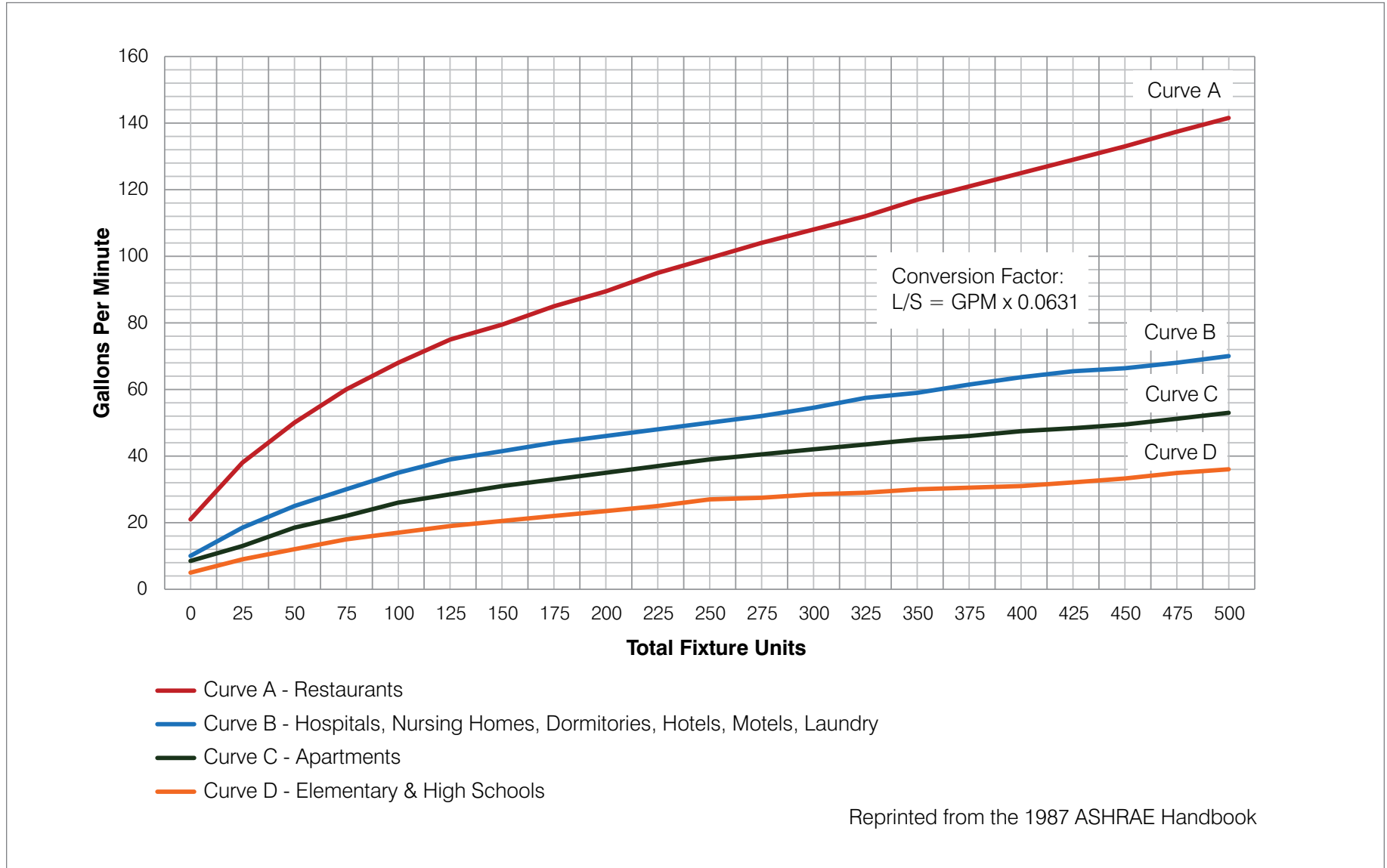

## Multiple NPE-240A2 or NPE-240S2 common venting

Additional model sizing & selection available online at Navieninc.com.

### Determining the length of a common vent system

Follow the instructions listed below to determine the length of a common vent.

1. Add the BTU/H input ratings for each unit in the cascading system to determine the total BTU/H rating.
2. Determine the Total Length (L) of the common vent, which consists of the Horizontal Width (W) and the Vertical Height (H): Total Length (L) = W+H.

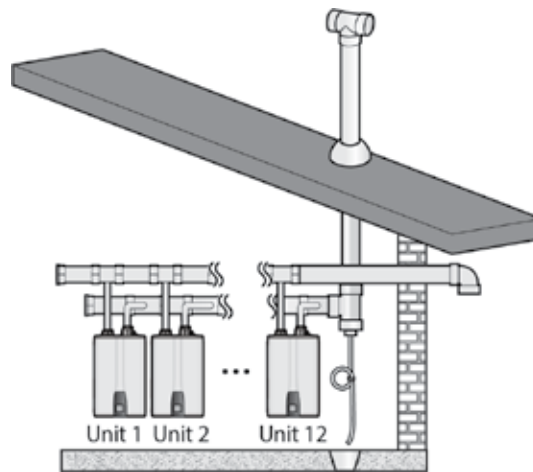

### Navien backflow damper (back-draft damper) 30014367B

The Navien backflow damper prevents backflow (back-draft) at the exhaust vent while the water heater unit operates.

By closing the exhaust vent as soon as the combustion cycle ends, the Navien backflow damper retains heat in the system for longer periods. This improves the system's thermal efficiency.

**NOTE** When using a common vent in a cascade system, backflow devices are required to prevent exhaust from entering the building.

### Included items:

Backflow Damper	Installation Manual	Ready-Link communication cable	Screw (4 ea)	VID jumper wire

### Common vent length table (Total Length [L] = W+H)

Vent length for NPE-2 water heater units

Required Load (Total BTU/H)	Model	Total Length (ft)			
		NPE-240 A2/S2	D=3"	D=4"	D=6"
399,800	2	60	106	200	
599,700	3	40	71	160	
799,600	4	30	53	120	
999,500	5		42	96	150
1,199,400	6		35	80	142
1,393,300	7		30	68	121
1,599,200	8			60	106
1,799,100	9			53	94
1,999,000	10			48	85
2,198,900	11			43	77
2,398,800	12			40	71

- NOTE**
- Every 90° elbow is used to 8 linear feet (2.4m) of vent length.
  - The maximum equivalent length of the branch pipe from the unit to the common vent trunk is 16 equivalent feet.
  - Branch pipe lengths are not added to the allowable equivalent vent lengths that are provided in the following charts.

## Formulas

General Formulas	
<b>Horsepower Water</b>	$= \frac{\text{GPM} \times \text{Head (ft.)} \times \text{Specific Gravity}}{3960}$
<b>Horsepower Brake</b>	$= \frac{\text{GPM} \times \text{Head (ft.)} \times \text{Specific Gravity}}{3960 \times \text{Pump Efficiency}}$
<b>Horsepower Brake</b>	$= \frac{\text{GPM} \times \text{PSI} \times \text{Specific Gravity}}{1713 \times \text{Pump Efficiency}}$
<b>Efficiency (Pump)</b>	$= \frac{\text{GPM} \times \text{Head (ft.)} \times \text{Specific Gravity}}{3960 \times \text{Pump BHP}}$
<b>Brake Horsepower (Motor)</b>	$= \frac{\text{Watts Input} \times \text{Motor Efficiency}}{746}$
<b>Pressure (lbs./sq. in.)</b>	$= \frac{\text{Head (ft.)} \times \text{Specific Gravity}}{2.31}$
<b>Head (ft.)</b>	$= \frac{\text{lbs./sq. in.} \times 2.31}{\text{Specific Gravity}}$
<b>GPM</b>	$= \frac{\text{BTU/H}}{500 \times \Delta T (^{\circ}\text{F})}$
<b><math>\Delta T (^{\circ}\text{F})</math></b>	$= \frac{\text{BTU/H}}{500 \times \text{GPM}}$
<b>Pressure (PSI)</b>	$= \frac{\text{Head (ft.)} \times \text{Specific Gravity}}{2.31}$
<b>Head (ft.)</b>	$= \frac{\text{Pressure (PSI)} \times 2.31}{\text{Specific Gravity}}$

Water Heating Formulas	
<b>% Efficiency</b>	$= \frac{\text{GPH} \times 8.34 \times \text{Temp. Rise} \times 1.0 \text{ (Specific Heat)}}{\text{BTU/H Input}}$
<b>BTU/H Output</b>	$= \text{GPH} \times 8.34 \text{ lbs./Gal.} \times \text{Temp. Rise} \times 1.0$
<b>BTU/H Input</b>	$= \frac{\text{GPH} \times 8.34 \times \text{Temp. Rise} \times 1.0}{\% \text{ Efficiency}}$
<b>GPH</b>	$= \frac{\text{BTU/H Input} \times \% \text{ Efficiency}}{\text{Temp. Rise} \times 8.34}$
<b>Rise (DF)</b>	$= \frac{\text{BTU/H Input} \times \% \text{ Efficiency}}{\text{GPH} \times 8.34}$
<b>KW</b>	$= \frac{\text{GPH} \times 8.34 \times \text{Temp. Rise} \times 1.0}{3413}$
<b>Determine % of Hot Water Portion</b>	$\frac{\text{MWT}-\text{C}}{\text{H}-\text{C}} = \frac{140-50}{180-50} = \frac{90}{130} = 69.2\% \text{ Hot Water}$
<b>Determine % of Cold Water Portion</b>	$\frac{\text{H}-\text{MWT}}{\text{H}-\text{C}} = \frac{180-140}{180-50} = \frac{40}{130} = 30.8\% \text{ Cold Water}$
	MWT = Mixed Water Temperature (°F) H = Hot Water Temperature (°F) C = Cold Water Temperature (°F)

Fluid Velocity Formulas	
<b>Velocity (ft./sec.)</b>	$= \frac{.408 \times \text{GPM}}{(\text{Pipe Diameter in Inches})^2}$
<b>Velocity Head (ft.)</b>	$= \frac{(\text{Pipe Velocity ft./sec.})^2}{64.4}$

## Navien NPE-240A2 or NPE-240S2 tankless water heater gallons per minute @ temperature rise

Temp rise (°F)	NPE-240 series GPM
35	11.2
40	9.8
45	8.7
50	7.8
55	7.1
60	6.5
65	6.0
70	5.6
75	5.2
80	4.9
85	4.6
90	4.4
100	3.9
110	3.6
120	3.3
130	3.0
140	2.8

## Specifications

Item		Model						
		NPE-150S2	NPE-180A2	NPE-180S2	NPE-210A2	NPE-210S2	NPE-240A2	NPE-240S2
Heat capacity (input)	Natural gas	18,000–120,000 BTU/H	10,000–150,000 BTU/H		12,000–180,000 BTU/H		13,300–199,900 BTU/H	
	Propane gas							
Efficiency ratings	UEF (NG & LP)	0.93	0.95	0.96	0.95	0.96	0.95	0.96
		35°F (19°C) temp rise		45°F (25°C) temp rise		67°F (36°C) temp rise		
Flow rate (DHW)	35°F (19°C) temp rise	6.8 GPM (26 L/m)	8.4 GPM (32 L/m)		10.1 GPM (38 L/m)		11.2 GPM (42 L/m)	
	45°F (25°C) temp rise	5.3 GPM (20 L/m)	6.5 GPM (25 L/m)		7.8 GPM (30 L/m)		8.7 GPM (33 L/m)	
	67°F (36°C) temp rise	3.4 GPM (13 L/m)	4.3 GPM (16 L/m)	4.4 GPM (17 L/m)	5.1 GPM (19 L/m)	5.3 GPM (20 L/m)	5.6 GPM (21 L/m)	5.8 GPM (22 L/m)
Dimensions		17.3"W x 27.4"H x 13.2"D						
Weight		62lbs (28kg)	73lbs (33kg)	68lbs (31kg)	77lbs (35kg)	73lbs (33kg)	77lbs (35kg)	73lbs (33kg)
Installation type		Indoor or outdoor wall-hung						
Venting type		Forced draft direct vent						
Ignition		Electronic ignition						
Water pressure		15–150 PSI						
Natural gas supply pressure (from source)		3.5"–10.5" WC						
Propane gas supply pressure (from source)		8"–13" WC						
Natural gas manifold pressure (min-max)		-0.04" WC to -0.40" WC	-0.03" WC to -0.55" WC		-0.03" WC to -0.76" WC		-0.03" WC to -0.96" WC	
Propane gas manifold pressure (min-max)		-0.03" WC to -0.40" WC	-0.02" WC to -0.55" WC		-0.02" WC to -0.76" WC		-0.02" WC to -0.96" WC	
Minimum flow rate		0.5 GPM (1.9 L/m), < 0.01 GPM (0.04 L/m) option for "A2" models*						
Connection sizes	Cold water inlet	3/4" NPT						
	Hot water outlet	3/4" NPT						
	Gas inlet	3/4" NPT						
Power supply	Main supply	120V AC, 60 Hz						
	Maximum power consumption	200W (max 2A), 350W (max 4A) with external pump connected						
Materials	Casing	Cold rolled carbon steel						
	Heat exchangers	Primary heat exchangers: stainless steel, secondary heat exchangers: stainless steel						
Venting	Exhaust	2" or 3" PVC, CPVC, polypropylene / 2" or 3" special gas vent type BH (Class II, A/B/C)						
	Intake	2" or 3" PVC, CPVC, polypropylene / 2" or 3" special gas vent type BH (Class II, A/B/C)						
	Vent clearances	0" to combustibles						
Safety devices	Flame rod, APS, ignition operation detector, water temperature high limit switch, exhaust temperature high limit sensor, power surge fuse, burner high limit fuse, vent installation detector (VID)							

\*Available for NPE-A2 models configured in an optional ComfortFlow® recirculation mode. Energy consumption will increase when the system is configured for recirculation.

Navien reserves the right to change specifications at any time without prior notice. Please refer to [www.Navieninc.com](http://www.Navieninc.com) to verify you have the most current information.





Navien Inc., 20 Goodyear, Irvine, CA 92618 800-519-8794 [navieninc.com](http://navieninc.com)  
Navien Canada, Inc., 555 Hanlan Rd., Unit 7 Vaughan, ON L4L 4R8 800-519-8794 [navieninc.ca](http://navieninc.ca)



**T H E L E A D E R I N C O N D E N S I N G T E C H N O L O G Y**